

MULTITEL MJ226

Nissan Cabstar PTT=3500kg

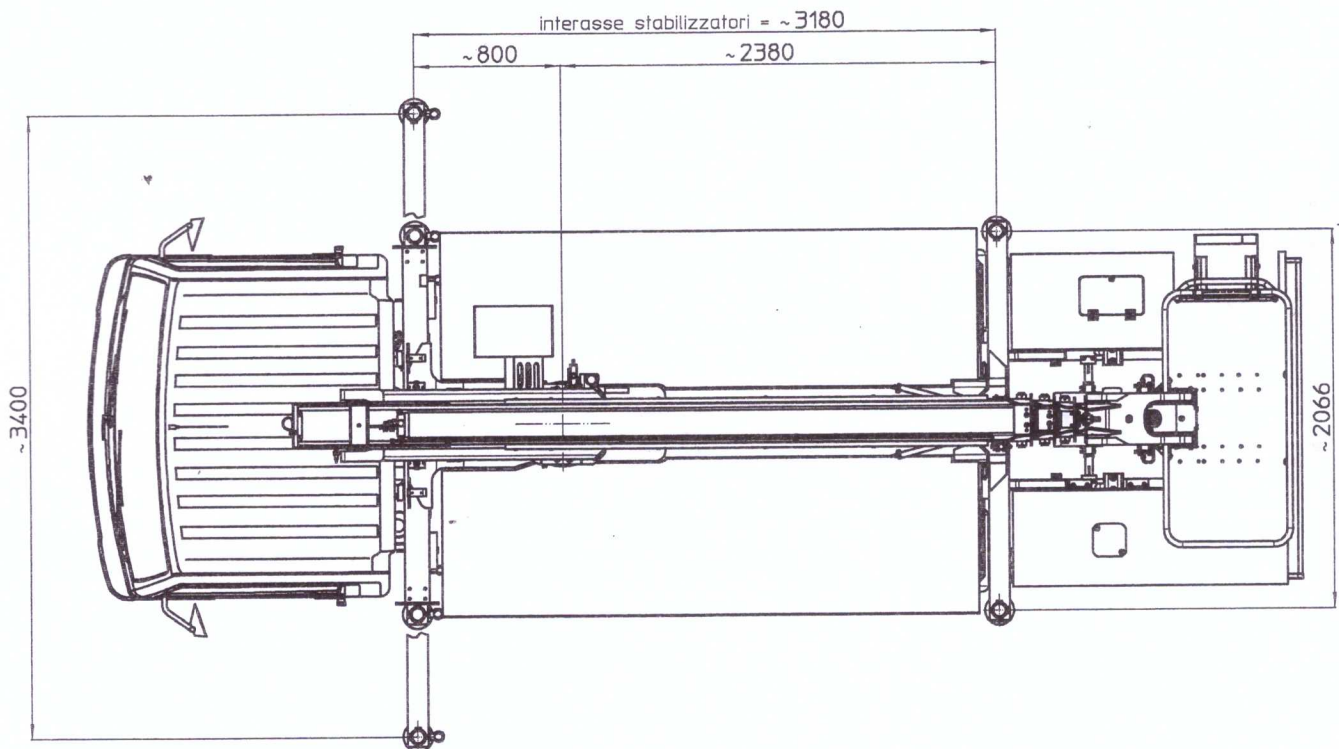
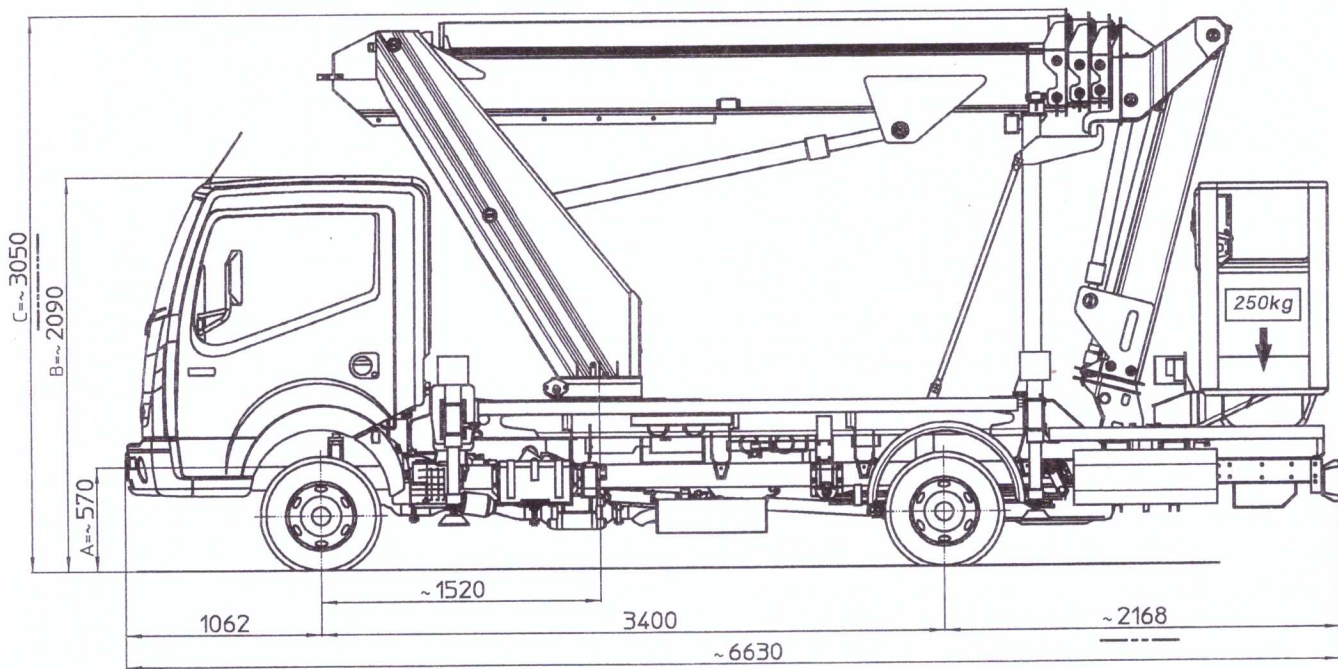

I - Le quote riportate in disegno sono indicative e possono subire variazioni. In particolare le quote A-B sono relative alle dimensioni dell'autocarro, quindi devono essere verificate sullo stesso. La quota C (altezza totale) e' subordinata alle quote A-B e non comprende eventuali parti flessibili.

F - Les cotes indiquées dans le dessin sont indicatives et peuvent subir des variations. En outre les cotes A-B sont relatives aux dimensions du porteur, donc elles doivent être vérifiées sur le porteur même. La cote C (hauteur totale) est subordonnée aux cotes A-B est indiquée hors flexibles.

E - The dimensions shown in the drawing are an indication and may undergo changes. Further the dimensions A-B are related to the truck sizes, therefore they must be verified. The dimension C (total height) is subject to A-B and does not include hoses.

D - Die Maße, die in der Zeichnung gezeigt werden, sind eine Anzeige und können Änderungen durchmachen. Die Abmessungen A-B betreffen die Fahrzeugmasse, daher sollen sie geprüft werden. Die Abmessung C (Gesamthöhe) hängt von A-B Abmessungen ab, die schlauche sind ausgeschlossen.

D56110

Ente	Rev.	Descrizione	Data	Dis.	Contr.	Ap.AQ
MRK	0	EMISSIONE	18/03/16	L.B.		
INGOMBRO - SCHEDA 54/1 - Rev. 0 - 15/12/00						

MULTITEL

MJ226

Ente	Rev.	Descrizione	Data	Dis.	Contr.	Ap.A0
MRK	0	EMISSIONE	01/04/16	L.B.		
DIAGRAMMA - SCHEDA 54/2 - Rev. 0 - 15/12/00						

D56233-M

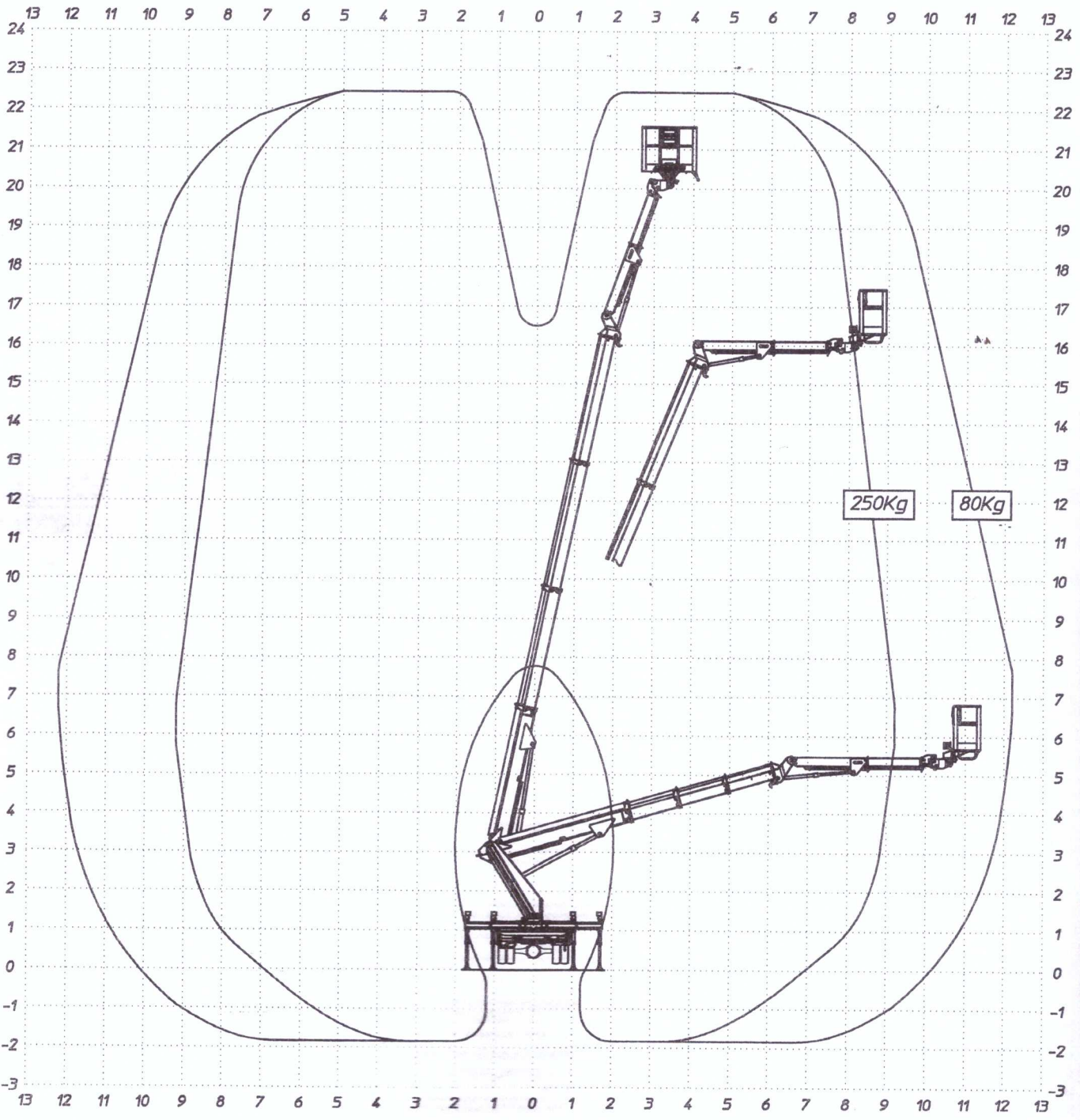

MULTITEL MJ226

Ente	Rev.	Descrizione	Data	Dis.	Contr.	Ap.AQ
MRK	0	EMISSIONE	05/04/16	A.D.		
DIAGRAMMA - SCHEDA 54/2 - Rev. 0 - 15/12/00						

D56232-M

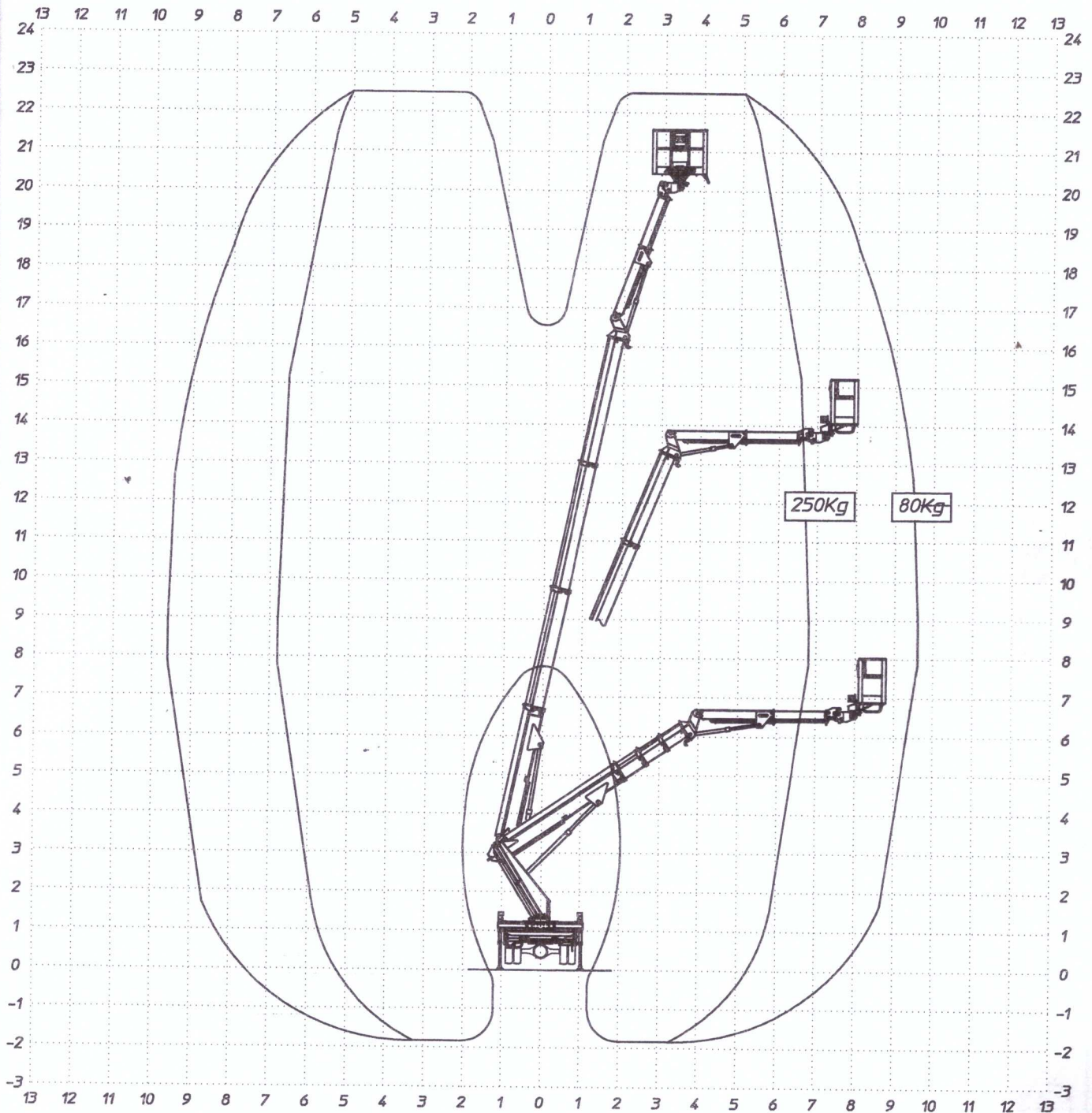

MULTITEL

MJ226

Ente	Rev.	Descrizione	Data	Dis.	Contr.	Ap.AQ
MRK	0	EMISSIONE	02/10/17	L.B.		
DIAGRAMMA - SCHEDA 54/2 - Rev. 0 - 15/12/00						

D61423-M

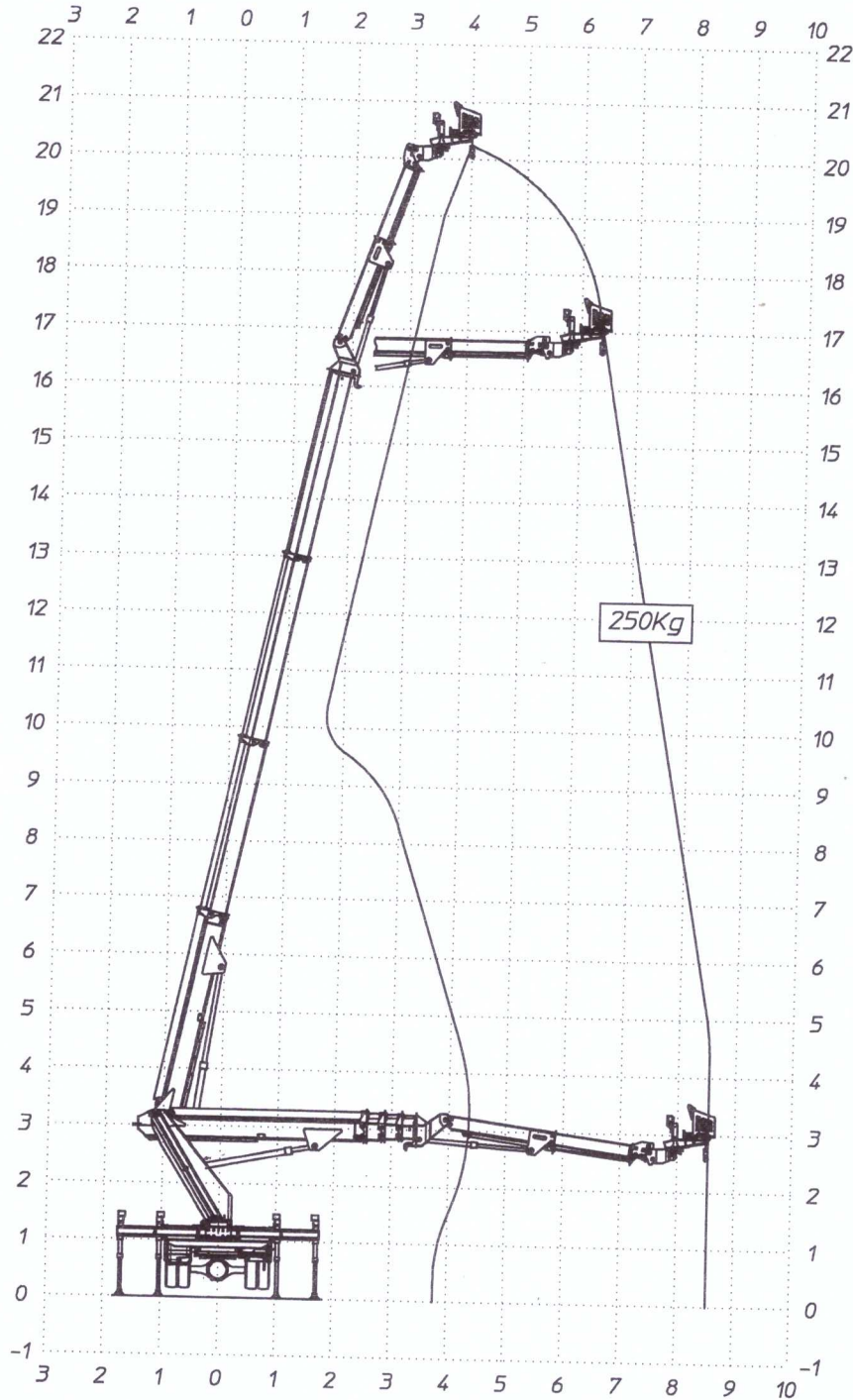

Macchina dotata di sistema di limitazione dello sbraccio a controllo di momento, le linee del grafico rappresentano le condizioni limite, ovvero con il carico massimo (carico nominale) e con il carico minimo (peso di una persona senza attrezzi - 80kg). Per ogni carico compreso tra questi due valori si ottiene una curva che sta tra le due linee tracciate.

Machine equipped with a movement control extension limit system. The graphic lines represent the limit conditions, meaning the maximum load (nominal load) and with a minimum load (weight of one person without tools - 80 kg). Every load between these two values obtains a curve that runs between the two marked lines.

Machine équipée d'un système de limitation de la portée à contrôle de moment, les lignes du graphique représentent les conditions limites, c'est-à-dire avec la charge maximum (charge nominale) et avec la charge minimum (poids d'une personne sans outils - 80 kg). Pour toute charge comprise entre ces deux valeurs, on obtient une courbe qui se situe entre les deux lignes tracées.

Die Maschine ist mit einem System zur Begrenzung der Ausladung mit Prüfmoment ausgestattet, die Grafiklinien stellen die Grenzbedingungen mit der maximalen Last (Nennlast) und der Mindestlast (Gewicht einer Person ohne Werkzeuge - 80 kg) dar. Für jede Last innerhalb dieser beiden Werte wird eine Kurve zwischen den beiden Linien erstellt.

MULLERTEL MJ222B

Ente	Rev.	Descrizione	Data	Dis.	Conti.	AppAO
MRK	0	EMISSIONE	05/04/16	A.D.		
INGOMBRO - SCHEDA 54/1 - Rev. 0 - 15/12/00						

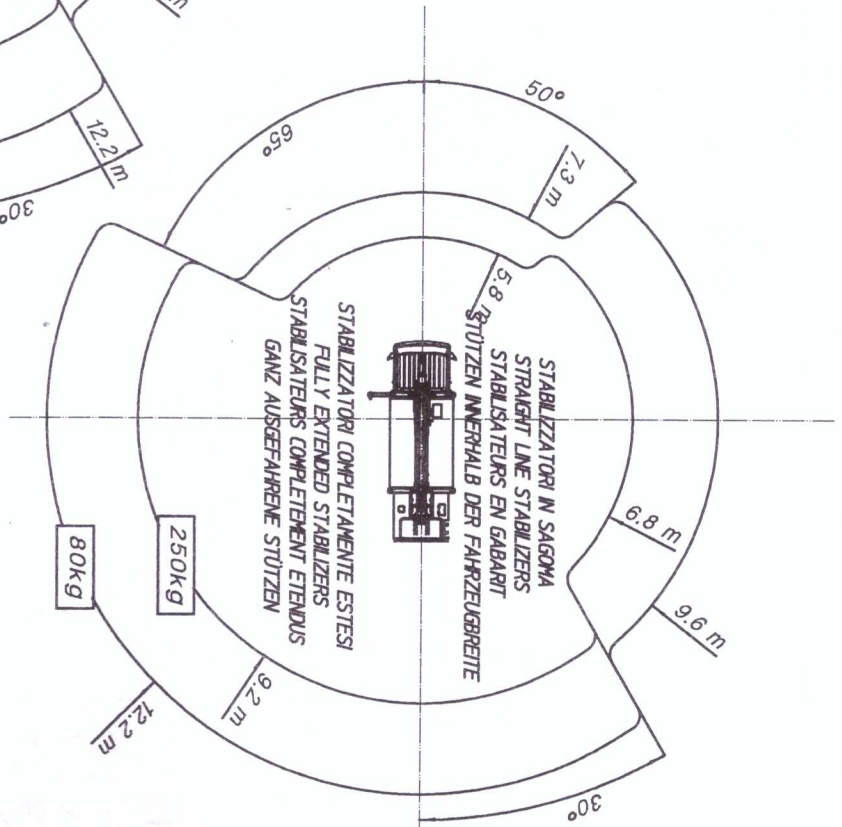
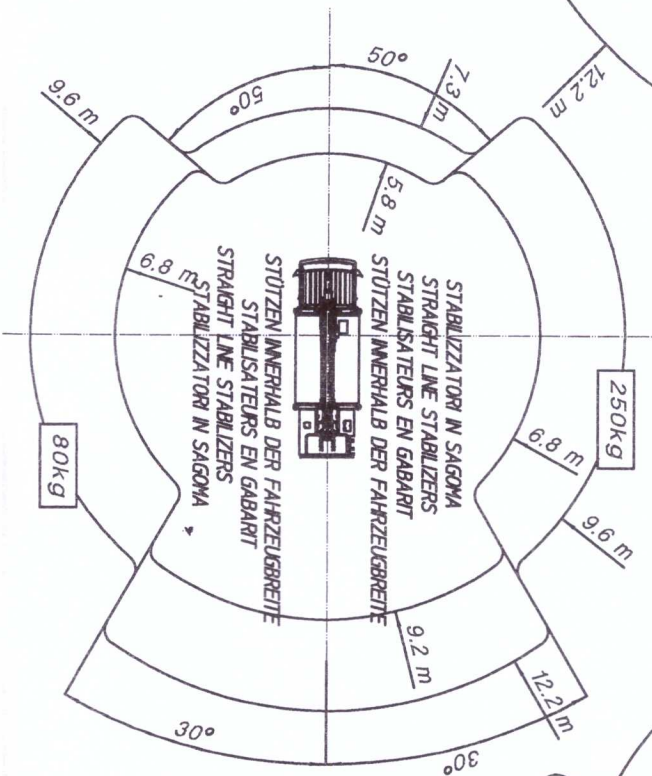
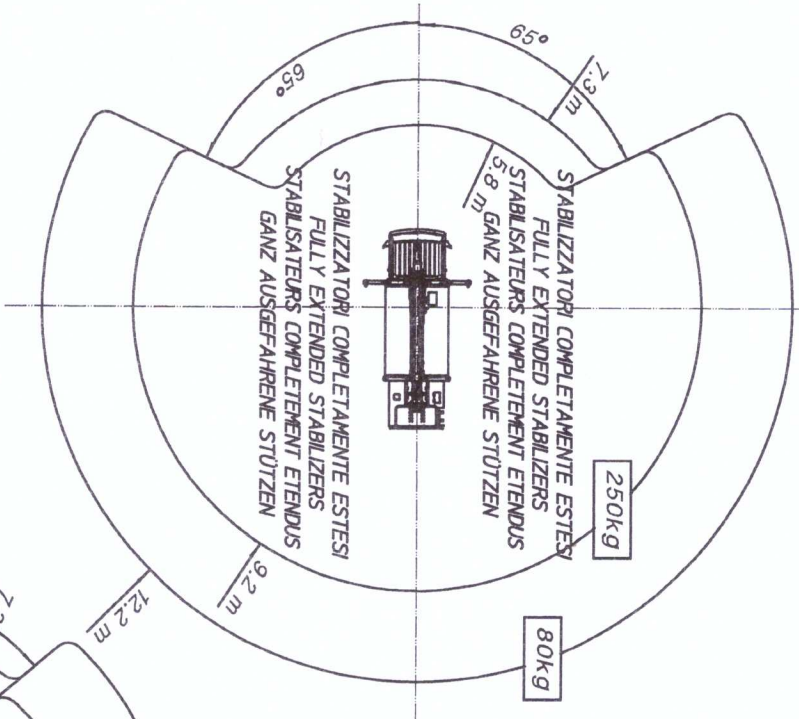

D56236-CE

MULLER M222B

Ente	Rev.	Descrizione	Data	Dis.	Contr.	Ap.AQ
MRK	0	EMISSIONE	02/10/17	L.B.		
INGOMBRO - SCHEDA 54/1 - Rev. 0 - 15/12/00						

D61424

