

# STEP 120



1106056-1106075-1106077-1106090-1106092 (230V/50Hz)

1106088 (230V 50Hz-60Hz)

1106097-1106098-1106099 (220V/60Hz)

1106054-1106055-1106086 (220V/60Hz TPH)

1106057-1106074-1106076-1106089-1106091-1106093-1106094-1106044-1106176-(400V/50Hz)

1106078-1106079-1106087 (400V/60Hz)



**I** INTONACATRICE

Manuale uso manutenzione e ricambi



**F** GUNITEUSE

Manuel utilisation entretien pieces de recharge



**GB** MORTAR MIXER

Operating, maintenance, spare parts manual



**D** VERPUTZMASCHINE

Handbuch für Bedienung, Wartung und Ersatzteile



**E** ENFOSCADORA

Manual de uso, mantenimiento y repuestos



**3226875 R16 (09/2018)**

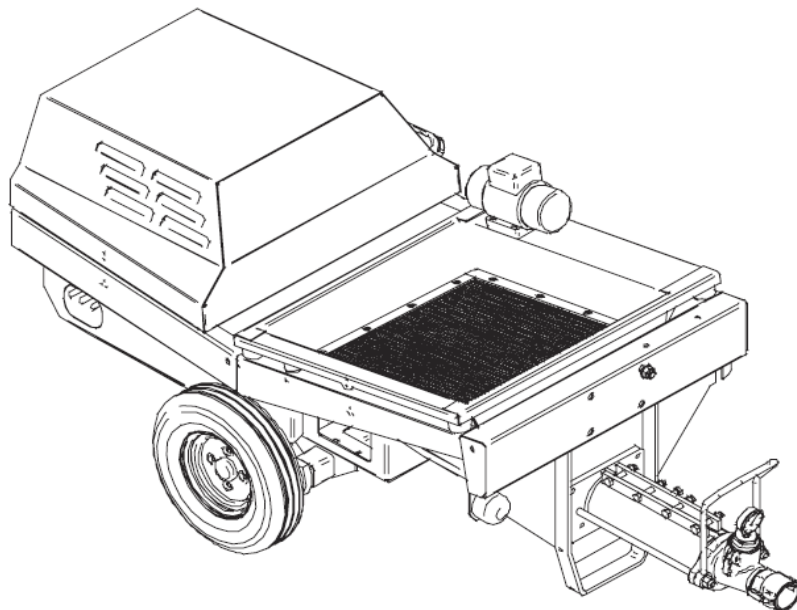

**IMER INTERNATIONAL S.p.A.**

Via Salceto, 55 - 53036 POGGIBONSI (SI) -(ITALY)

Tel. 0577 97341 - Fax 0577 983304

[www.imergroup.it](http://www.imergroup.it)

**1106086-1106087-1106088-1106089-1106090-1106091-1106094-  
1106095-1106069-1106097-1106099**  
**VERSIONE NON STRADALE - PAS VERSION DE RUE -  
NOT STREET VERSION - NICHTSTRASSE VERSION -  
NO VERSIÓN DE LA CALLE**

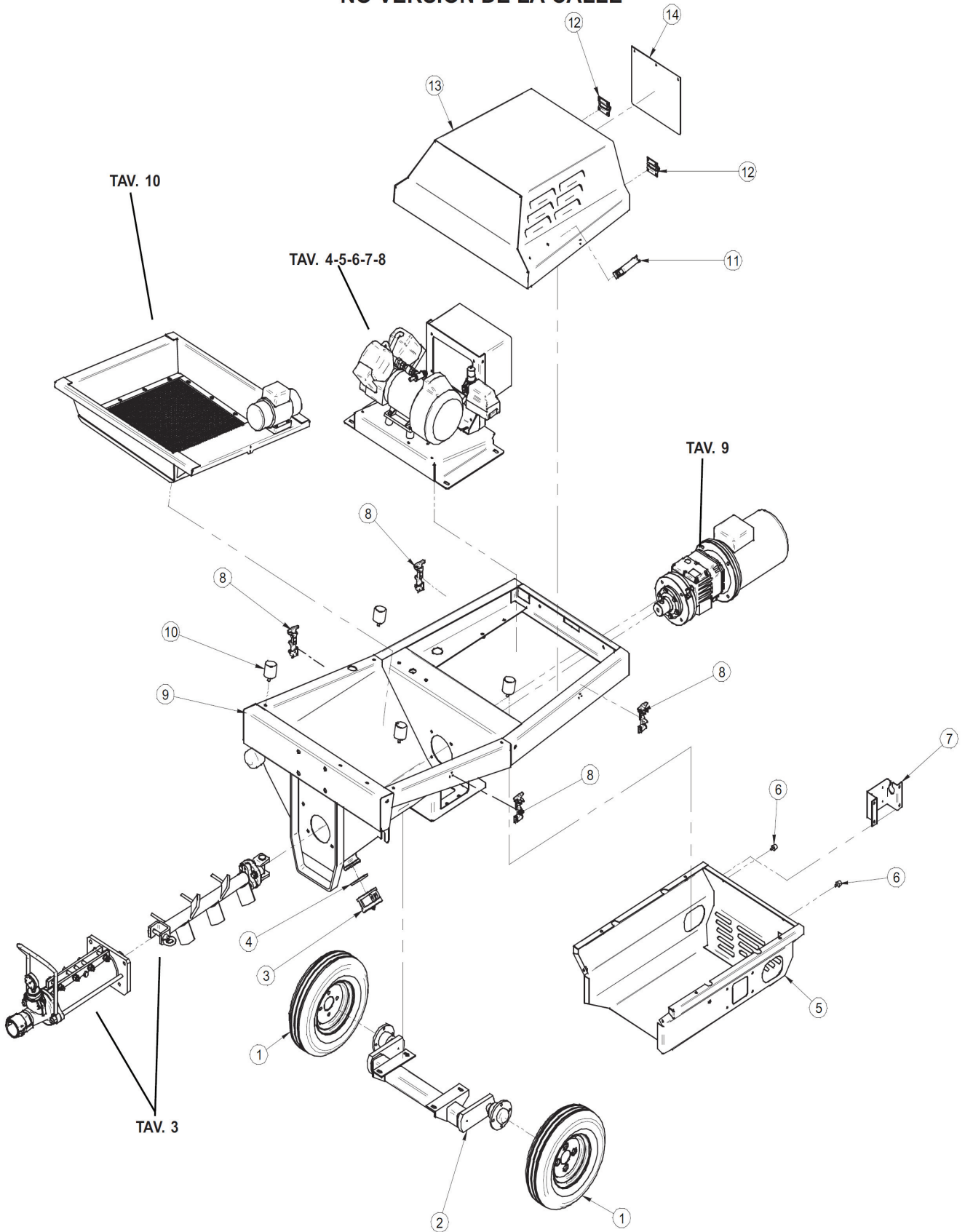

Documentazione senza certificazione CE  
Documentation without CE certificate

**TAV. 1 - STRUTTURA MACCHINA - STRUCTURE MACHINE - MACHINE STRUCTURE - MASCHINENAUFBAU - ESTRUCTURA DE LA MAQUINA**

Rif.	Cod.	I	F	GB	D	E	Note
1	3231197	RUOTA	ROUE	WHEEL	RAD	RUEDA	PN.400x90 2.50-8 FIAT
2	3236443	ASSALE	ESSIEU COMPLET	COMPLETE AXLE	ACHSE KOMPLETT	EJE COMPLETO	KG.700
3	3225751	TAPPO FEMMINA	BOUCHON KAMLOCK F.	KAMLOCK PLUG F.	KAMLOCK VER- SCHLUSS F.	TAPON KAMLOCK F.	TIPO DC PER DN65
4	3225891	GUARNIZIONE ATTACCO A CAMME DN65	JOINT DE RACCORD À CAMES DN 65	SEAL CAM COUPLING DN 65	DICHTUNG F. NOCKE- NANSCHLUSS DN 65	GUARNICIÓN RACOR TIPO CAMLOCK DN 65	DN65
5	3227949	CARTER INFERIORE	CARTER INFÉRIEUR	CATER INFERIOR	KURBELKASTEN NIE- DRIGER	CÁRTER DESECHO	
6	3224801	ANTIVIBRANTE	SUPPORT ANTIVIBRA- TILE	VIBRATION DAMPER	SCHWINGUNGS- DÄMPFER	ANTIVIBRADOR	GN 17 0315 70 SHORE
7	3226813	SUPPORTO SCATOLA PRESA VIBROVAGLIO	SUPPORT TBLEAU ELECTRIQUE CRIBLE VIBRANT	VIBRATING SCREEN ELECTRICAL PANEL SUPPORT	RÜTTELSIEB RAHMEN SCHALTAFEL	BASE CUADRO ELÉCTRICO TAMIZ VIBRATORIO	
8	3225776	CHIUSURA VALPA	FERMETURE	CLOSURE	SCHLIESSEN	CIERRE	ART. 1016 ZINC.
9	3225964	TELAIO	CHASSIS	FRAME	RAHMEN	BASTIDOR	
10	3225826	ANTIVIBRANTE	SUPPORT ANTIVIBRA- TILE	VIBRATION DAMPER	SCHWINGUNGS- DÄMPFER	ANTIVIBRADOR	GN 17 0319
11	3204888	MANIGLIA	POIGNEE	HANDLE	GRIFF	MANIJA	
12	3224625	CERNIERA PER FUR- GONI	CHARNIERE POUR FOURGONS ZINGUEE	GALV. HINGE FOR VANS	SCHARNIER FÜR LIE- FERWAGEN VERZINKT	BISAGRA PARA FURGO- NES ZINC.	ZINC.
13	3227948	SPORTELLO	PORTE	DOOR	KABINENKLAPPE	PORTEZUELA	
14	3226811	LASTRA DI PRO- TEZIONE QUADRO ELETTRICO	PROTECTION ELECTRI- QUE CRIBLE	ELECTRICAL PANEL PROTECTION	SCHNECKEN	PROTECCIÓN	

Documentazione senza certificazione CE  
 Documentation without CE certificate

1106092-1106093-1106098

**VERSIONE STRADALE CON MESCOLATRICE -VERSION DE RUE AVEC MALAXEUR -  
STREET VERSION WITH MIXING - STRASSE VERSION MIT MISCHER-  
VERSIÓN DE LA CALLE CON MEZCLADORA**

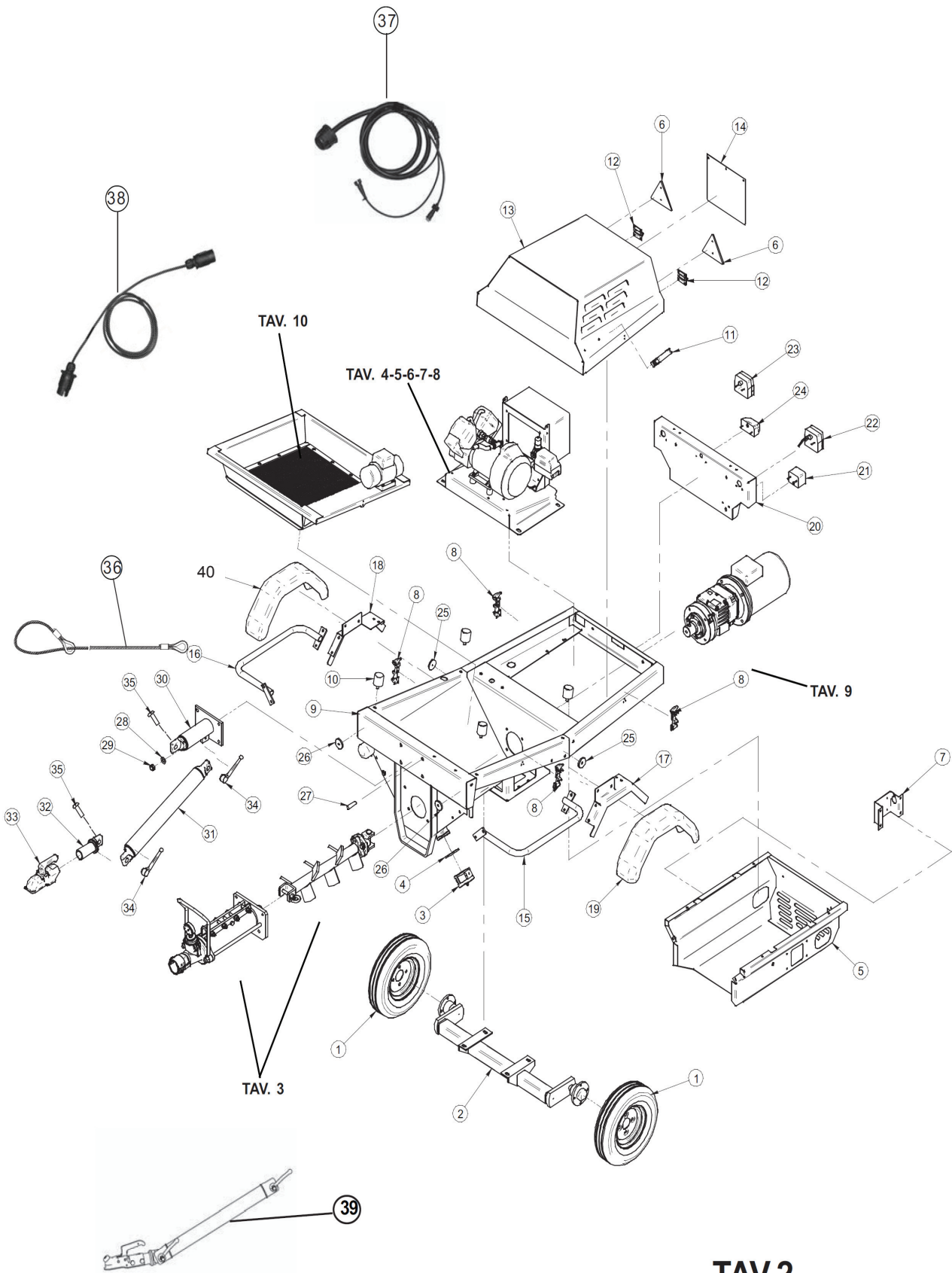

**TAV.2**

Documentazione senza certificazione CE  
Documentation without CE certificate



TAV. 2 - VERSIONE STRADALE CON EMSCOALTRICE - VERSION DE RUE AVEC MALAXEUR - STREET VERSION WITH MIXING - STRASSE VERSION MIT MISCHER - STRASSE VERSION CON MEZCLADORA								
Da matricola	Rif.	Cod.	I	GB	D	E	Note	
	1	3226275	RUOTA	ROUE	WHEEL	RAD	RUEDA	PN.400/8 CER-CHIO 2.50-8 FIAT
	2	3227733	ASSALE	ESSIEU COMPLET	COMPLETE AXLE	ACHSE KOMPLETT	EJE COMPLETO	700 KG
	3	3225751	TAPPO FEMMINA	BOUCHON KAMLOCK F.	KAMLOCK PLUG F.	KAMLOCK VER-SCHLUSS F.	TAPON KAMLOCK F.	TIPO DC PER DN65
	4	3225891	GUARNIZIONE ATTACCO A CAMME DN65	JOINT DE RACCORD A CAMES DN 65	SEAL CAM COUPLING DN 65	DICHTUNG F. NOCKE-NANSCHLUSS DN 65	GUARNICIÓN RACOR TIPO CAMLOCK DN 65	DN65
	5	3226272	CARTER INFERIORE	CARTER INFÉRIEUR	CATER INFERIOR	KURBELKASTEN NIE-DRIGER	CÁRTER DESECHO	
	6	3226720	CATADRIOTTO ROSSO TRIANGOLARE	REFLÉCHISSANT TRIANGULAIRE	TRIANGULAR RED REFLECTOR	RÜCKSTERAHLER ROT DREICKIG	REFLEXIVO ROJO TRIANGULAR	
	7	3226813	SUPPORTO SCATOLA PRESA VIBROVAGLIO	SUPPORT TBLEAU ELECTRIQUE CRIBLE VIBRANT	VIBRATING SCREEN ELECTRICAL PANEL SUPPORT	RÜTTELSIEB RAHMEN SCHALTAFEL	BASE CUADRO ELÉCTRICO TAMIZ VIBRATORIO	
	8	3225776	CHIUSURA VALPA	FERMETURE	CLOSURE	SCHLIESSEN	CIERRE	ART. 1016 ZINC.
	9	3225964	TELAIO	CHASSIS	FRAME	RAHMEN	BASTIDOR	
	10	3225826	ANTIVIBRANTE	SUPPORT ANTIVIBRA-TILE	VIBRATION DAMPER	SCHWINGUNGS-DÄMPFER	ANTIVIBRADOR	GN 17 0319
	11	3204888	MANIGLIA	POIGNEE	HANDLE	GRIFF	MANIJA	
	12	3224625	CERNIERA PER FUR-GONI	CHARNIERE POUR FOURGONS ZINGUEE	GALV. HINGE FOR VANS	SCHARNIER FÜR LIE-FERWAGEN VERZINKT	BISAGRA PARA FURGO-NES ZINC.	ZINC.
	13	3226310	SPORTELLLO	PORTE	DOOR	KABINENKLAPPE	PORTEZUELA	
	14	3226811	LASTRA DI PRO-TEZIONE QUADRO ELETTRICO	PROTECTION ELECTRI-QUE CRIBLE	ELECTRICAL PANEL PROTECTION	SCHNECKEN	PROTECCIÓN	
F009441725	15	3233312	BARRA ANTICICLISTI-CA SX	BARRE ANTICYCLISTE GAUCHE	SIDE IMPACT BAR LH.	FAHRRADSCHUTZSTAB	BARRA ANTICICLISTA IZQ.	
F009441725	16	3233313	BARRA ANTICICLISTI-CA DX	BARRE ANTICYCLISTE DROITE	SIDE IMPACT BAR RH.	FAHRRADSCHUTZ-STAB LI.	BARRA ANTICICLISTA DER.	
F009441725	17	3233355	SUPPORTO PARAFAN-GO SX	SUPPORT DE GARDE-BOUE GAUCHE	MUDGUARD SUPPORT LH	KOTFLÜGELHALTE-RUNG RE.	SOPORTE GUARDA-BARROS IZQ.	
F009441725	18	3233356	SUPPORTO PARAFAN-GO DX	SUPPORT DE GARDE-BOUE DROITE	MUDGUARD SUPPORT RH	KOTFLÜGELHALTE-RUNG RE.	SOPORTE GUARDA-BARROS DER	
	19	3236391	PARAFANGO SX	GARDE-BOUE SX	MUDGUARD SX	KUNSTSTOFFKOT-FLÜGEL SX	GUARDABARROS SX	
F009441725	20	3233374	BARRA LUCI POSTE-RIORE	BARRE ECLAIRGE	LIGHT BAR	LEUCHTEINLEISTE	BARRA DE LUCES	NEW
	21	3226719	LUCE RETRONEBBIA CON CAVO E CONNET-TORE	LANTERNE ANTI-BROUILLARD	ANTIFOG LIGHT	SCHEINWERFER ANTIFOG	FARO ANTINEBLA	ASPOCK K37.6603.037
F009441725	22	3233397	FANALE	LANTERNE GAUCHE	LIGHT LH.	SCHEINWERFER LI.	FARO IZQ.	
F009441725	23	3233397	FANALE	LANTERNE DROITE	LIGHT RH	SCHEINWERFER RE.	FARO DER	
	25	3224855	CATADRIOTTO GIALLO	REFLÉCHISSANT	REFLECTOR YLLOW	RÜCKSTERAHLER GELGB	REFLEXIVO	D.60
	26	3224854	CATADRIOTTO BIANCO	REFLÉCHISSANT BLANC	REFLECTOR WHAITE	RÜCKSTERAHLER AMBESCHRIBEN	REFLEXIVO BLANCO	D.60
	27	3225828	PRIGIONIERO	BOULON PRISIONNER	STUD BOLT	STIFSCHRAUBE	PERNO PRISIONERO	5911 M16X40 Z
	28	2224640	RONDELLA	RONDELLE PLATE	PLAIN WASHER	FLACHE UNTER-LEGSCHIEBE	ARANDELA PLANA	UNI6593 M16 DE 33 X3 Z
	29	3223930	DADO	ECROU AUTOBLOQUANT	SELF-LOCKING NUT	SELBSTSICHERNDE MUTTER	TUERCA AUTOBLO-QUEANTE	DIN985 M16 CLASSE 8
F009441725	30	3233094	ATTACCO PRIMARIO TIMONE	RACCORD PRIMAIRE D'ATTELAGE	PRIMARY CONNECTION	ANGREIFEN FÜHREND STÜCK	CONEXIÓN PRIMARIO	
	31	3225923	BRACCIO INTERMEDIO TIMONE	BRAS INTERMEDIAIRE	MIDDLE ARM	DEICHSELZWISCHEN-STÜCK	BRAZO INTERMEDIO	
	32	3225922	ATTACCO TESTINA TRAINO	RACCORD TETE D'AT-TELAGE	TOWING HEAD CON-NECTION	ANSCHLUSS ZUGAUGE	CONEXIÓN CABEZAL REMOLQUE	
	33	3209959	TASTINA AGGANCIIO TIMONE	TETE D'ATTELAGE	TOWING HEAD	ZUGAUGE	CABEZAL REMOLQUE	
	34	3225924	LEVA REGOLAZIONE TIMONE	LEVIER DE REGLAGE	ADJUSTMENT LEVER	EINSTELLHEBEL	PALANCA DE REGU-LACIÓN	
	35	3227807	PERNO DI BLOCCAG-GIO	BOULON DE BLOCAGE	LOCKING PIN	SICHERUNGSBOLZEN	PERNO DE FIJACIÓN	
	36	3225284	CAVETTO SICUREZZA	CORDE DE SÛRETÉ	SECURITY CORD	KABEL SICHERHEIT	CUERDA DE SEGU-RIDAD	
F009441725	37	3233398	CABLAGGIO FANALI	CAPTEUR LANTERNE	WIRING LIGHTS	VERDRAHTUNG SCHEINWERFER	CABLEADO FARI	
	38	3226172	PROLUNGA ELETTRICA	PROLONGE ÉLECTRI-QUE	PROLONGS ELECTRIC	VERLÄNGERUNG ELEKTRISCH	PROLONGA ELÉCTRICO	
F009441725	39	3233083	GRUPPO TIMONE + TESTINA	TIMON+TETE D'ATTE-LAGE	DRAWBAR+TOWING HEAD	DEICHSELENDE+ ZUGAUGE	TIMON+CABEZA RE-MOLQUE	
	40	3236390	PARAFANGO DX	GARDE-BOUE DX	MUDGUARD DX	KUNSTSTOFFKOT-FLÜGEL DX	GUARDABARROS DX	

Documentazione senza certificazione CE

Documentazione senza certificazione CE  
Documentazione without CE certificate

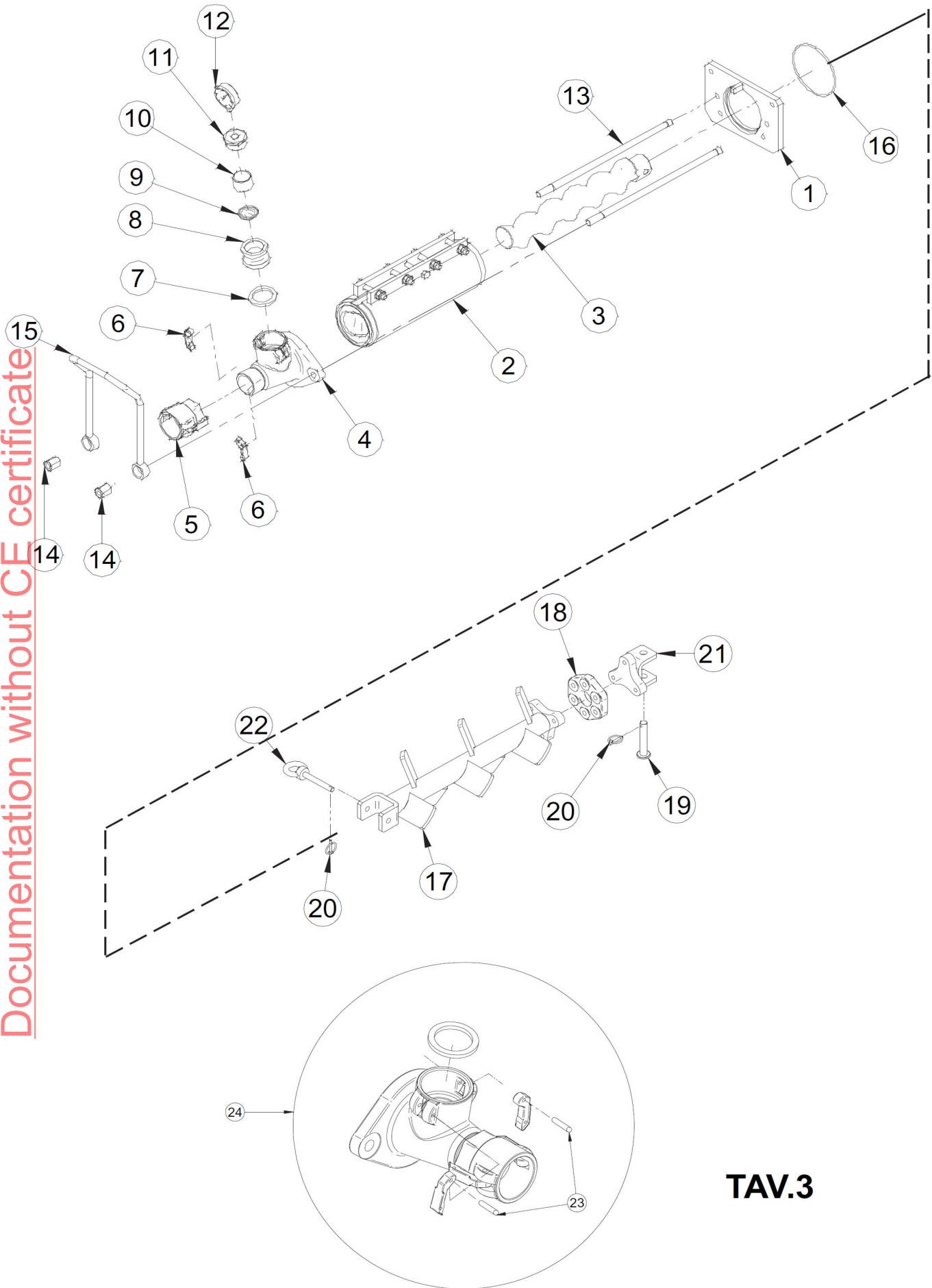

**TAV.3**



TAV.3 GRUPPO POMPA - GROUPE POMPE - PUMP GROUP - BÜSCHEL PUMPE - GRUPO BOMBA							
Rif.	Cod.	I	F	GB	D	E	Note
1	3226253	FLANGIA SUPPORTO VITE IM25	FLASQUE SUPPORT DE VIS	SCREW SUPPORT FLANGE	HALTERUNGSFLANSCH SCHNECKE	BRIDA SOPORTE TORNILLO	IM25
2	1107110	STATORE IM 25L	STATOR	STATOR	STATOR	ESTATOR	IM25 L
3	1107111	ROTORE IM 25L	ROTOR	ROTOR	ROTOR	ROTOR	IM25 L
4	3224390	COLLETTORE DI MANDATA	COLLECTEUR DE REFOULEMENT	DELIVERY MANIFOLD	DRUCKSEITIGE SAMMELLEITUNG	COLECTOR DE IMPULSIÓN	
5	3224492	ATTACCO A CAMME DN50 F-2" G-F	RACCORD EXENTRIQUE DN50 F-2" G-F	CAM-LOCK COUPLING DN50 F-2" G-F	NOCKENANSCHLUSS DN50 B-2" GAS-B	CONEXIÓN DE LEVA DN50 F-2" G-H	DN50 F-2" G F
6	3224498	LEVA ATTACCO A CAMME	LEVIER	LEVER	HEBEL	PALANCA	DN 25-35-50
7	3224499	GUARNIZIONE ATTACCO A CAMME DN 50	JOINT DE RACCORD À CAMES DN 50	SEAL CAM COUPLING DN 50	DICHTUNG F. NOCKENANSCHLUSS DN 50	GUARNICIÓN RACOR TIPO CAMLOCK DN 50	DN50
8	3224500	ATTACCO MANOMETRO	PRISE MANOMETRE	PRESSURE GAUGE CONNECTION	MANOMETER-ANSCHLUSS	CONEXIÓN MANÓMETRO	
9	3223392	MEMBRANA	MEMBRANE	MEMBRANA	MEMBRAN	MEMBRANA	
10	3225275	ANELLO DISTANZIALE PER MEMBRANA	ENTRETOISE POUR MEMBRANE	SPACER RING FOR MEMBRANE	DISTANZRING FÜR MEMBRAN	ANILLO SEPARADOR PARA MEMBRANA	
11	3224173	RIDUZIONE	REDUCTION M1-1/2" - F1/2" LAITON	REDUCTION M1-1/2" - F1/2" BRASS	REDUZIERSTÜCK M1-1/2" - F1/2" MESSING	REDUCCIÓN M1-1/2" - F1/2" LATÓN	M 1 1/2"-F 1/2" OTTONE
12	3223689	MANOMETRO	MANOMETRE D=63 0-100 BAR 1/4"	PRESSURE GAUGE D=63 0-100BAR- CONN. 1/4"	MANOMETER D=63 0-100 BAR- ANSCHL. 1/4"	MANÓMETRO D=63 0-100 BARES- CON. 1/4"	0-100 BAR ATT.1/4"
13	3226934	TIRANTE COLLETTORE DI MANDATA IM 25L	TIRANT DE COLLECTEUR DE REFOULEMENT	DELIVERY MANIFOLD STAY	VERSTREBUNG DRUCKSEITIGE SAMMELLEITUNG	TIRANTE COLECTOR DE IMPULSIÓN	
14	3224395	DADO M16 SPECIALE	ECROU SPECIAL	SPECIAL NUT	SPEZIALMUTTER	TUERCA ESPECIAL	M 16
15	3226378	MANIGLIA DI TRASPORTO	POIGNEE	HANDLE	GRIFF	MANIJA	
16	3224356	ANELLO OR	BAGUE	RING	RING	ANILLO	OR 4525
17	3225367	ALBERO TRAMOGGIA	VIS TREMIE	HOPPER SCREW FEEDER	TRICHTERSCHNECKE	SINFÍN TOLVA	
18	3224340	GIUNTO TRASMISSIONE ELASTICO	JOINT (OU ACCOUPLEMENT) ARBRE TREMIE	HOPPER SHAFT JOINT	KUPPLUNG TRICHTERWELLE	JUNTA EJE DE TOLVA	
19	3224341	PERNO DI BLOCCAGGIO	BOULON DE BLOCAGE	LOCKING PIN	SICHERUNGSBOLZEN	PERNO DE FIJACIÓN	D=16
20	3224628	COPIGLIA A SCATTO	GOUPILLE	SPLIT PIN	RASTSPLINT	PASADOR DE DISPARO	D=4.5
21	3226361	FORCELLA PER GIUNTO ELASTICO	FOURCHE JOINT (OU ACCOUPLEMENT) ARBRE TREMIE	HOPPER SHAFT JOINT FORK	KUPPLUNG TRICHTERWELLE GABEL	HORQUILLA JUNTA EJE DE TOLVA	
22	3226941	PERNO CON GOLFARE	BOULON DE BLOCAGE	LOCKING PIN	SICHERUNGSBOLZEN	PERNO DE FIJACIÓN	D.12
23	3226640	SPINA	GOUJON	PIN	STIFT	CHAVETA	
24	3228329	COLLETTORE DI MANDATA COMPLETO	COLLECTEUR DE REFOULEMENT COMPLET	DELIVERY MANIFOLD COMPLETE	DRUCKSEITIGE SAMMELLEITUNG COMPLETE	COLECTOR DE IMPULSIÓN COMPLETO	

Documentazione senza certificazione CE  
Documentation without CE certificate

Documentazione senza certificazione CE  
Documentation without CE certificate

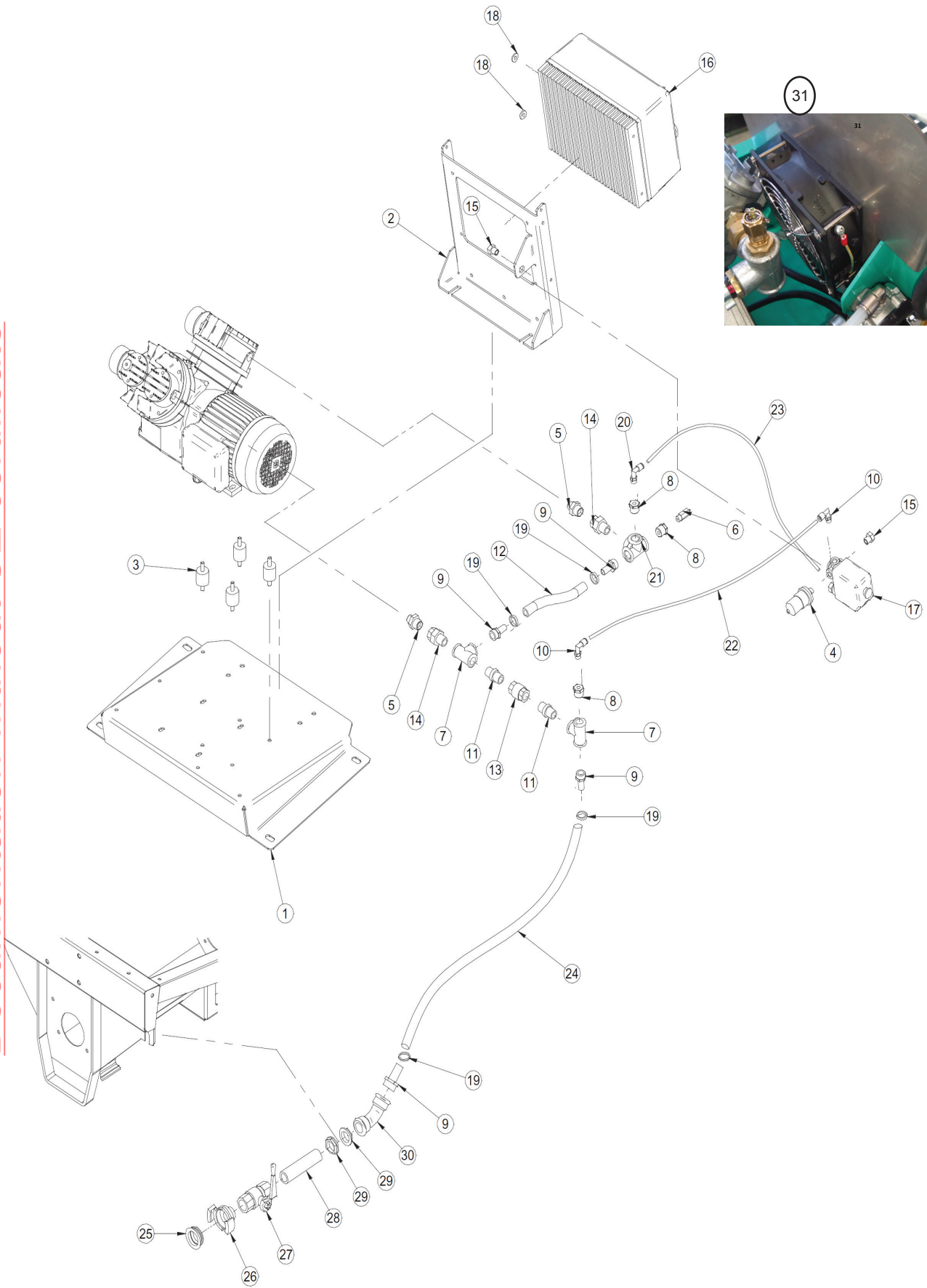





TAV.4 COMPRESSORE 220V - COMPRESSEUR 220V - COMPRESSOR 220V - VERDICHTER 220V - COMPRESOR 220

DA MATRICOLA DE NOMBRE SÉRIE UP TO SERIAL NUMBER DE NUMERO DE SERIE	Rif.	Cod.	I	F	GB	D	E	Note
	1	3226271	PIASTRA SUPPORTO COMPRESSORE	PLAQUE DE SUPPORT COMPRESSEUR	COMPRESSOR PLATE SUPPORT	VERDICHTERPLATTE LAGER	PLACA BASE COMPRESOR	
	2	3226273	SUPPORTO QUADRO ELETTRICO	SUPPORT TBLEAU ELECTRIQUE	ELECTRICAL PANNEL SUPPORT	LAGER SCHALTAFEL	BASE CUADRO ELÉCTRICO	
	3	3226864	ANTIVIBRANTE	SUPPORT ANTIVIBRANTE	VIBRATION DAMPER	SCHWINGUNGS-DÄMPFER	ANTIVIBRADOR	M8X20
	4	3223630	PRESSOSTATO	PRESSOSTAT	PRESSURE SWITCH	DRUCHSCHALTER	PRESOSTATO	GP600 1/4" CILINDRICO 1-5BAR
	5	3224928	NIPLES RIDOTTO	NIPLES REDUIT	REDUCED NIPPLE	NIPPLE REDUZIERSTÜCK	NIPLE REDUCTOR	1/2"-3/8" CONICO GHISA Z
	6	3224593	VALVOLA DI SICUREZZA	SOUPAPE DE SOURPRESSION	RELIEF VALVE	DRUCKBREGENZUNGS-VENTIL	VALVULA DE MAXIMA	
	7	3223617	RACCORDO "T"	RACCORD	COUPLING	VERBINDUNGSDTCK	RACOR	T 1/2" F.F.F.
	8	3223609	RIDUZIONE	RÉDUCTION	REDUCER	REDUZIERSTÜCK	REDUCCIÓN	M. 1/2" F.1/4" OTTONE
	9	3223613	PORTAGOMMA	EMBOUT DE TUYAU AIR	HOSE CLAMP	SCHLAUCHHALTER	NIPLES	M.1/2"X13
	10	3224345	RACCORDO ARIA 90°	RACCORD	COUPLING	VERBINDUNGSDTCK	RACOR	GIREV.INN.RAPID. 1/4" PER TUBO 8/6
	11	3224362	NIPLES	NIPLES	REDUCED	NIPPLE	NIPLE	1/2"
	12	3224608	TUBO AIR WATER	TUYAU	HOSE	SCHLAUCH	MANGUERA	13X20 20BAR L.170mm
	13	3224360	VALVOLA DI RITENUTA	SOUPAPE DE SOURPRESSION	RELIEF VALVE	DRUCKBREGENZUNGS-VENTIL	VALVULA DE MAXIMA	1/2" F.F.
	14	3223618	BOCCHETTONE	EMBOUT	CAP	KAPPE	BOCA	M.F A SEDE CCONICA 1/2"
	15	3225126	TAPPO OLEODINAMICO	BOUCHON M.	PLUG M.	VERSCHLUSS M.	TAPON M.	1/4" CILINDRICO SV. 60°
3007466	16	3229670	QUADRO ELETTRICO	TBLEAU ELECTRIQUE	ELECTRICAL PANNEL	SCHALTAFEL	CUADRO EL CTRICO	230V 50HZ
	17	3225843	PRESSOSTATO	PRESSOSTAT	PRESSURE SWITCH	DRUCHSCHALTER	PRESOSTATO	MIGNON 4 VIE 1/4"
	18	3224581	RONDELLA SPECIALE IN NYLON	RONDELLE NYLON	NYLON WASHER	UNTERLEGSSCHEIBE NYLON	ARANDELA NYLON	
	19	3225073	FASCETTA STRINGITUBO	COLLIER	CLAMP	SCHELLE	ABRAZADERA	D.17-20
3003406	20	3223884	RACCORDO ARIA 90°	RACCORD	COUPLING	VERBINDUNGSDTCK	RACOR	GIREV.INN.RAPID. 1/4" CONICO PER TUBO 8/6
3003406	21	3227964	DISTRIBUZIONE A "T" 1/2"	RÉPARTITION "T" 1/2"	DISTRIBUTION "T" 1/2"	VERBREITUNG "T" 1/2"	DISTRIBUCIÓN "T" 1/2"	
3003406	22	1272701	TUBO ARIA	TUYAU	HOSE	SCHLAUCH	MANGUERA	D.8/6 L.40CM
3003406	23	3226816	TUBO ARIA	TUYAU	HOSE	SCHLAUCH	MANGUERA	D.6/4 L.40cm
	24	3224608	TUBO AIR WATER	TUYAU	HOSE	SCHLAUCH	MANGUERA	20 BAR 13X20 L.1200 mm
	25	3223697	GUARNIZIONE ATTACCO RAPIDO	JOINT DE RACCORD EXCENTRI UE	QUICK COUPLING GASKET	DICHTUNG SCHNELLKUPPLER	JUNTA CONEXIÓN RÁPIDA	
	26	3224203	ATTACCO RAPIDO	RACCORD RAPIDE	QUICK CONNECTOR	SCHNELLVERBINDUNG	EMPALME RAPIDO	1/2"M.
	27	3224202	VALVOLA SFERA	BOISSEAU SPHERIQUE	BALL VALVE	KUGELVENTIL	VÁLVULA ESFERA	1/2" F.F.
	28	3223957	TRONCHETTO FILETTATO	EMBOUT DE TUBE FILETE	THREADED BRANCH	GEWINDESTUTZEN	VÁSTAGO ROSCADO	M 1/2" L.85MM OTTONE
	29	3223730	GHIERA FLANGIATA	FRETTE NICKELÉE	NICKEL-PLATED FLANGED RING NUTA	FLANSCHNUT VERNICKELT	VIROLA EMBRIDADA NIQUELADA	NICHELATA 1/2"
	30	3224205	CURVA AMPIO RAGGIO 45°	COUDE GRAND RAYON	WIDE RADIUS BEND	GROSSE KURVE	CURVA AMPLIO RADIO	1/2" F.F.
	31	3234995	KIT VENTILAZIONE	KIT REFROIDISSEMENT	COOLING KIT	KIT AUSSENKÜHLUNG	KIT ENFRIAMIENTO	

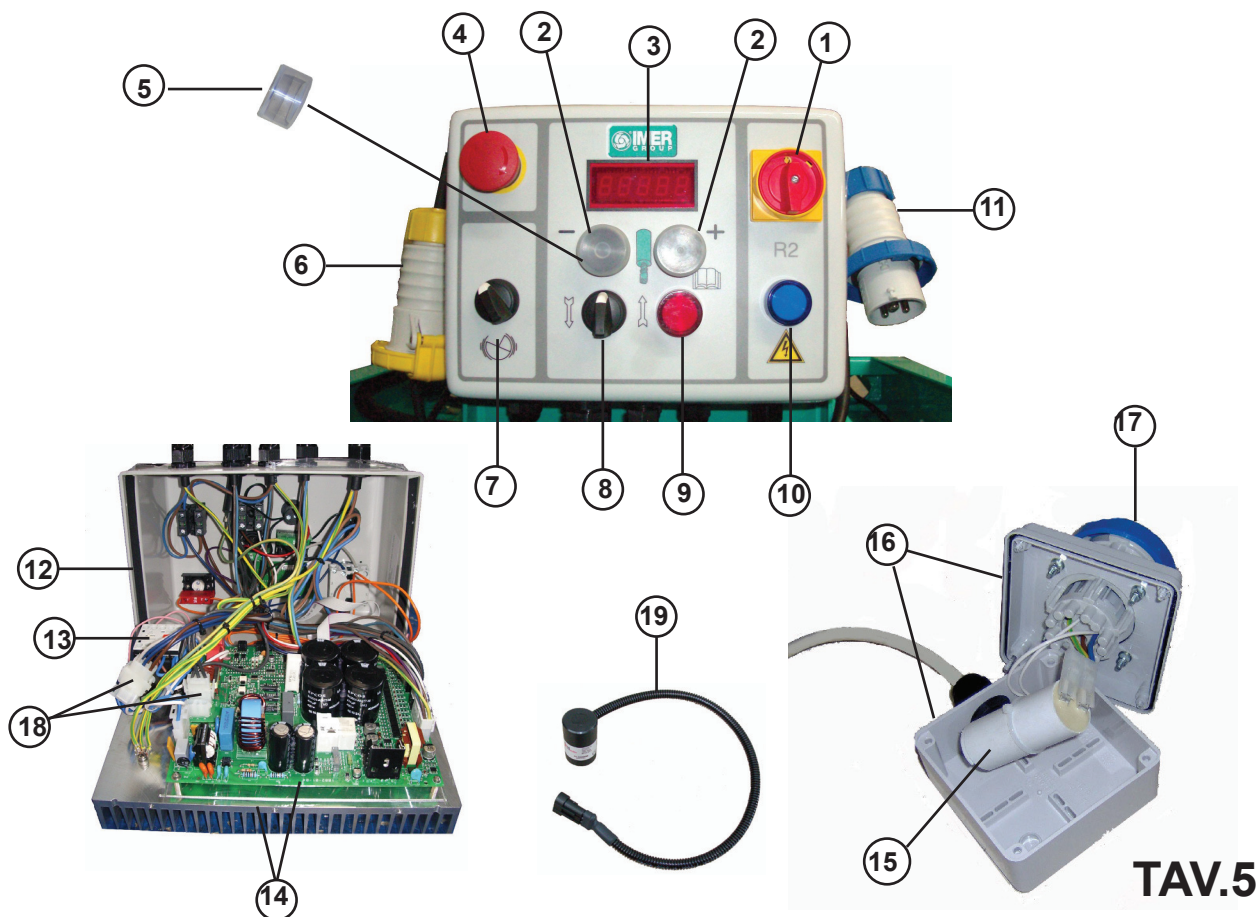

TAV. 5 - QUADRO ELETTRICO STEP220V (3229670)- TABLEAU ÉLECTRIQUE STEP220V (3229670)-  
ELECTRICAL PANEL STEP220V (3229670) - SCHALTAFEL STEP220V (3229670) - CUADRO ELÉCTRICO STEP220V (3229670)  
DA MATRICOLA:3007466  
FROM SERIAL NUMBER:3007466  
À PARTIR DU NUMÉRO DE ÉRIE:3007466  
VON SERIENNUMMER:3007466  
À PARTIR DU NUMÉRO DE SÉRIE:3007466

RIF.	COD.	I	F	GB	D	E	Note
1	3230316	SEZIONATORE	SECTIONNEUR	CUT-OUT SWITCH	TRENNSCHALTER	INTERRUPTOR	
2	3225437	PULSANTE CON PROTEZIONE IN GOMMA+CONTATTI	POUSSOIR AVEC PROTECTION EN CAOUTCHOUC+CONTACTS	PUSHBUTTON WITH RUBBER PROTECTION +CONTACTS	DRUCKTASTE MIT GUMMISCHUTZ + KONTAKTE	BOTÓN CON PROTECCIÓN DE GOMA + CONTACTOS	
3	3229742	DISPLAY	BOUCLIER	DISPLAY	SCHILD	BLINDAJE	
4	3225440	PULSANTE EMERGENZA+CONTATTI	BOUTON D'ARRÊT D'URGENCE+CONTACTS	EMERGENCY PUSHBUTTON +CONTACTS	NOT-AUS-TASTER+KONTAKTE	BOTÓN EMERGENCIA + CONTACTOS	
5	3226932	PROTEZIONE IN GOMMA	PROTECTION EN CAOUTCHOUC	RUBBER PROTECTION	GUMMISCHUTZ	PROTECCIÓN DE GOMA	
6	3230313	SPINA	FICHE	PLUG	WANDSTECKER	ENCHUFE	16A 4H 110-130V 3P+T IP67
7	3230317	INTERRUPTORE 2 POSIZIONI+CONTATTI	INTERRUPTEUR 2 POSITIONS+CONTACTS	2-POSITION SWITCH +CONTACTS	SCHALTER 2 STELL.+KONTAKTE	INTERRUPTOR 2 POSICIONES + CONTACTOS	
8	3230318	INTERRUPTORE 2POSIZIONI RITORNO SX+CONTATTI	INTERRUPTEUR 2 POSITIONS RETOUR GAUCHE+CONTACTS	2-POSITION SWITCH LH RETURN+CONTACTS	SCHALTER 2 STELL. RÜCKK.LI+KONTAKTE	INTERRUPTOR 2 POSICIONES RITORNO IZQ + CONTACTOS	
9	3230449	PORTALAMPADA COMPLETO ROSSO+LED 24 VD	DOUILLE COMPLÈTE ROUGE+LED 24 VDC	LAMP HOLDER ASSEMBLY RED+LED 24 VDC	KOMPLETTE LAMPENFASSUNG ROT+LED 24 VDC	PORTALÁMPARA COMPLETO ROJO + LED 24 VDC	24 VDC
10	3230448	PORTALAMPADA COMPLETO BLU+LED 24 VDC	DOUILLE COMPLÈTE BLEUE+LED 24 VDC	LAMP HOLDER ASSEMBLY BLUE +LED 24 VDC	KOMPLETTE LAMPENFASSUNG BLAU+LED 24 VDC	PORTALÁMPARA COMPLETO AZUL + LED 24 VDC	24 VDC
11	3203504	SPINA	FICHE	PLUG	WANDSTECKER	ENCHUFE	230V 2P+T 16A 6H IP67
12	3229833	COPERCHIO INVERTER STEP 120 230V	COUVERCLE INVERTER STEP 120 230V	STEP 120 230V INVERTER COVER	DECKEL F. INVERTER STEP 120 230V		
13	3230320	CONTATTORE					20A 24VDC
14	3230071	SCHEDA INVERTER STEP 230V	CARTE INVERTER STEP 230V	INVERTER CARD STEP 230V	PLATINE INVERTER STEP 230V	TARJETA INVERTER STEP 230V	
15	3227794	CONDENSATORE	CONDENSATEUR	CAPACITOR	KONDENSATOR	CONDENSADOR	10 mF 450V 50-60 Hz
16	3230315	SCATOLA+COPERCHIO	CAISSE+COUVERCLE	ELECTRICAL BOX+COVER	ELEKTRISCH BOX+DECKEL	CAJÓN ELÉCTRICO+TAPA	
17	3228278	PRESA A PARETE DIRITTA	PRISE MURALE DIR	STRAIGHT WALL PLUG	DIR.WANDSTECKDOSE	TOMA DE PARED DIR.	200/250V 3P+T 16A 9H IP67
18	3230319	KIT CABLAGGI + CONNETTORI	KIT CÂBLAGES ET CONNEXEURS	WIRING CONNECTOR KIT	KABEL- UND STECKER-SATZ	KIT DE CABLEADOS Y CONECTORES	
19	3226898	SENSORE MAGNETICO	CAPTEUR MAGNÉTIQUE	MAGNETIC SENSOR	SENSOR MAGNETISCH	SENSOR MAGNÉTICO	

Documentazione senza certificazione CE  
Documentazione without CE certificate

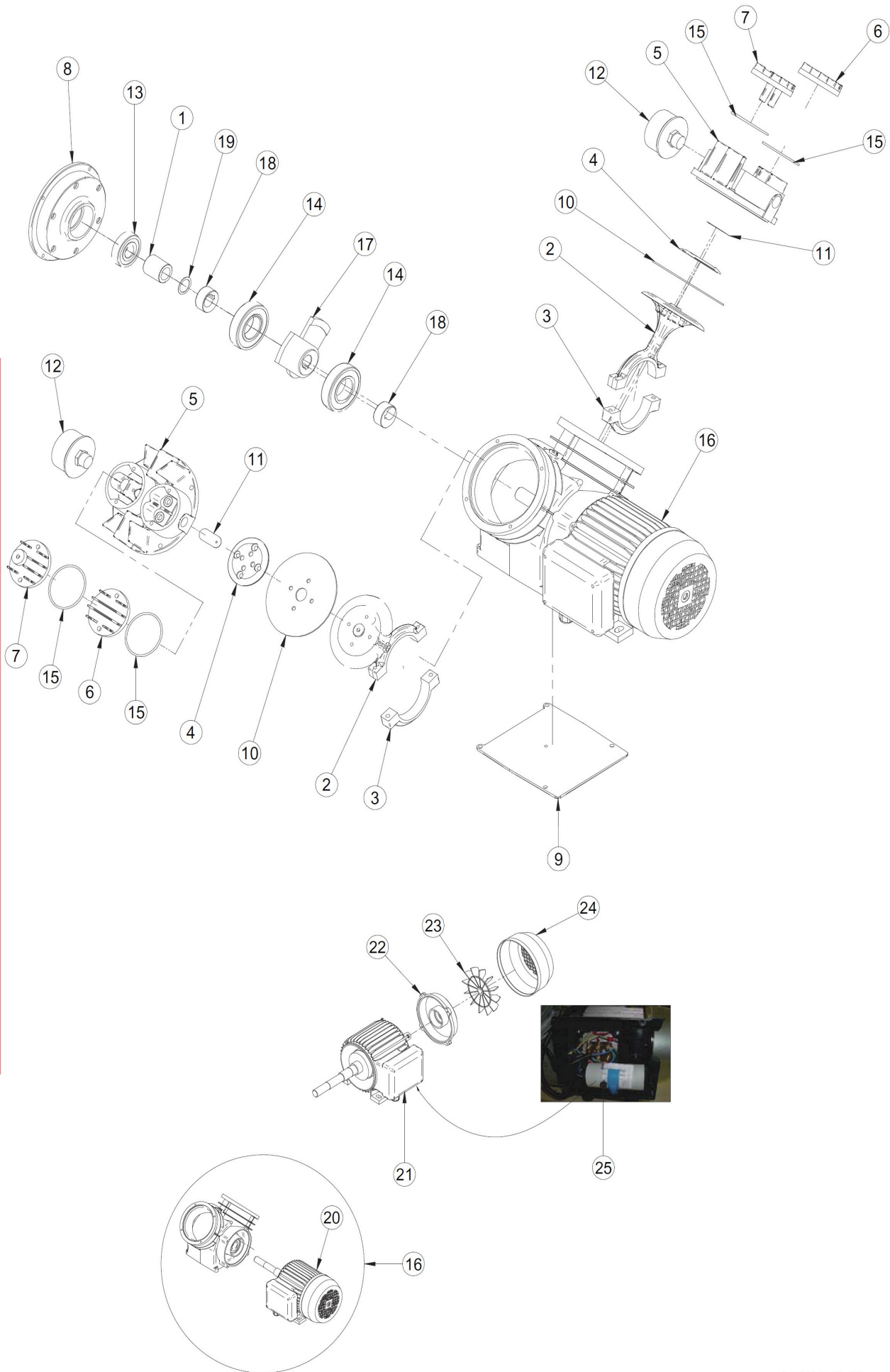

**TAV.6 COMPRESSORE 220V - COMPRESSEUR 220V - COMPRESSOR 220V - VERDICHTER 220V - COMPRESOR 220**

DA MATRICOLA DE NOMBRE SÉRIE UP TO SERIAL NUMBER DE NUMERO DE SERIE	Rif.	Cod.	I	F	GB	D	E	Note
	1	3224332	DISTANZIALE COM- PRESSORE	ENTRETOIS	SPACER	AUSEINANDERLEGEN	DISTANCIAR	
	2	3224529	BIELLA	BIELLE	CONROD	PLEUEL	BIELA	
	3	3224530	TESTA BIELLA	TÊ TÊ DE BIELLE	CON ROD HEAD	PLEUELFUSS	CABEZAL BIELA	
	4	3224531	FERMO MEMBRANA	ARRÊ T DE MEMBRANE	MEMBRANE RETAI- NER	MEMBRANHALTER	TOPE MEMBRANA	
	5	3224532	TESTA	TETE	HEAD	ZYLINDERKOPF	CABEZAL	
	6	3224533	TAPPO DX	BOUCHON DROIT	RH CAP	RE. VERSCHLUSS	TAPÓN DER.	
	7	3224534	TAPPO SX	BOUCHON GAUCHE	LH CAP	LI. VERSCHLUSS	TAPÓN IZQ.	
	8	3224536	COPERCHIO	COUVERCLE	COVER	DECKEL	TAPA	
	9	3224537	PIASTRA COMPRES- SORE	PLAQUE DE COMPRES- SEUR	COMPRESSOR PLATE	VERDICHTERPLATTE	PLACA COMPRESOR	
	10	3224539	MEMBRANA COMPRES- SORE	MEMBRANE DE COM- PRESSEUR	COMPRESSOR MEM- BRANE	MEMBRAN F. VER- DICHTER	MEMBRANA COMPRES- SOR	
	11	3224548	LAMELLA	LAMELLE DE COMPRES- SEUR	COMPRESSOR PLATE	LAMELLE F VER- DICHTER	LÁMINA COMPRESOR	
	12	3224844	FILTRO COMPRES- SORE	FILTRE DE COMPRES- SEUR	COMPRESSOR FILTER	VERDICHTERFILTER	FILTRO COMPRESOR	
	13	3224859	CUSCINETTO	ROULEMENT	BEARING	LAGER	COJINETE	6304 2RSH SKF
	14	3224860	CUSCINETTO	ROULEMENT	BEARING	LAGER	COJINETE	6207 2RS1 SKF
	15	3224867	ANELLO OR	BAGUE	RING	RING	ANILLO	OR 3243
3003406	16	3228021 (230V/50HZ) 3228162 (220V/60HZ)	SCATOLA COMPRES- SORE+ MOTORE 230V	BOITIER COMPRESSEUR + MOTEUR	COMPRESSOR HOUSING+MOTOR	VERDICHTERGEHÄUSE +MOTOR	CAJA COMPRESOR+MOTOR	
	17	3226966	ECCENTRICO BILAN- CIERE	CAME	CAM	NOCKEN	EXCÉNTRICO	
	18	3226967	BOCCOLA ECCEN- TRICA	DOUILLE CAME	CAM BUSH	NOCKEN BUCHSE	CASQUILLO EXCÉN- TRICO	
	19	3227154	ANNELLO COMPEN- SATORE	BAUGE	RING	RING	ANILLO	LMKAS 28A (27.8X0.5=1.7)
3003406	20	3228228 (230V/50HZ) 3228237 (220V/60HZ)	STATORE	STATOR	STATOR	STÄNDER	ESTATOR	
	21	3226375	SCATOLA ELETTRICA CON COPERCHIO	CAISSE ÉLECTRIQUE+ COUVERCLE	ELECTRICAL BOX+COVER	ELEKTRISCH BOX+DECKEL	CAJÓN ELÉCTRICO+TAPA	
	22	3226531	FLANGIA MOTORE ELETTRICO	FLASQUE MOTEUR	FLANGE ENGINE	FLANSCH MOTOR	BRIDA MOTOR	
	23	3226532	VENTOLA MOTORE	ROUBE À AUBES	FAN	ANTREIBER	IMPULSOR	
	24	3226533	COPRIVENTOLA MOTORE	COUVERCLE ROUBE À AUBES	COVER FAN	DECKEL ANTREIBER	TAPA IMPULSOR	
	25	3226183	CONDENSATORE DI MARCIA	CONDENSATEUR	CAPACITOR	KONDENSATOR	CONDENSADOR	MF 25 450 VAC 5 0 HZ

 Documentazione senza certificazione CE  
 Documentation without CE certificate

**TAV.7 GRUPPO COMPRESSORE 400V 50/60HZ - 220V 60HZ TRIFASE -  
GROUPE COMPRESSEUR 400V 50/60HZ - 220V 60HZ TRIPHASÉ -  
GROUP COMPRESSOR 400V 50/60HZ - 220V 60HZ TPH -  
BÜSCHEL VERDICHTER 400V 50/60HZ - 220V 60HZ DREIPHASIGEN-  
GRUPO COMPRESOR 400V 50/60HZ - 220V 60HZ TRIFASICO**

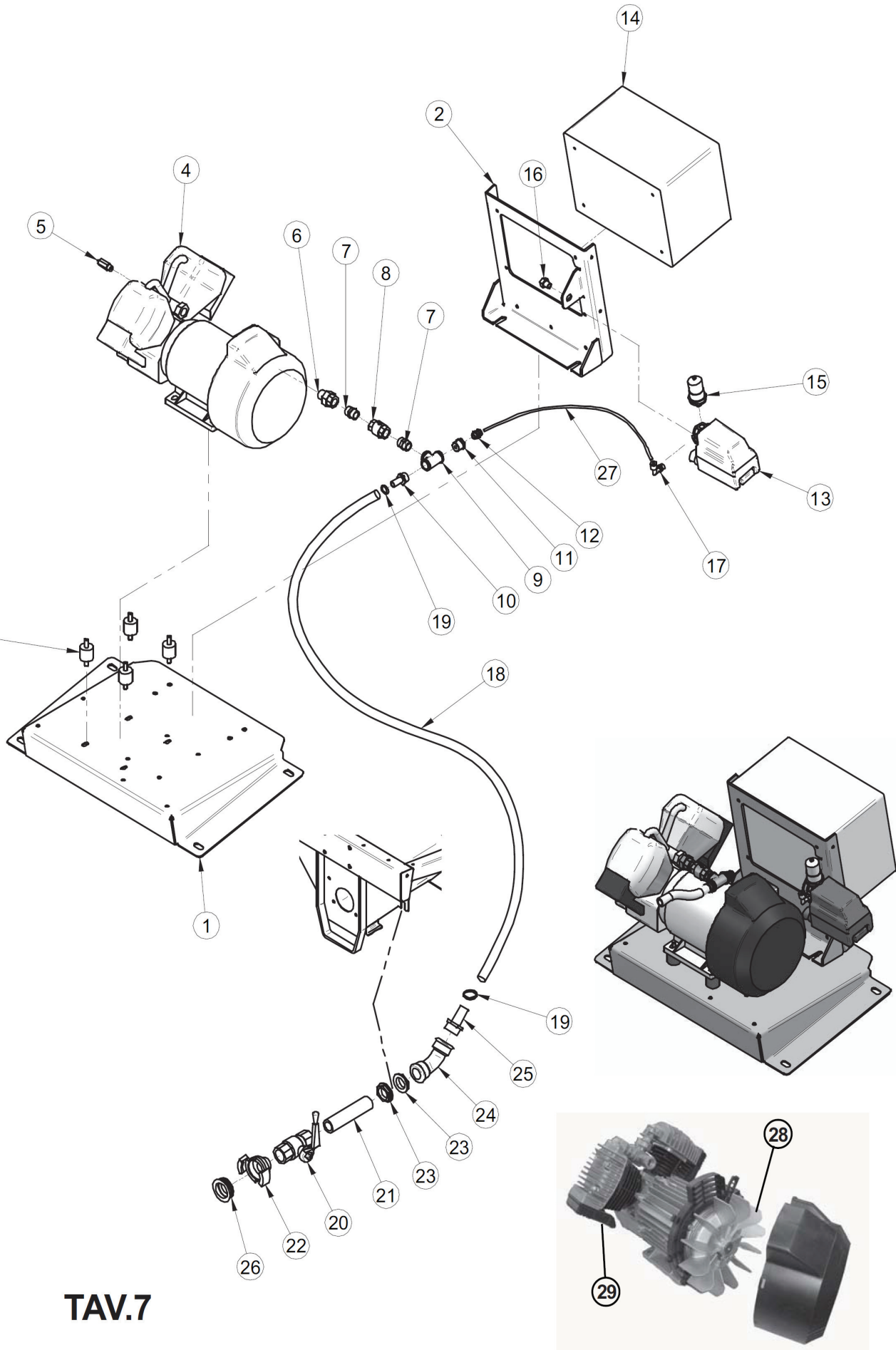

**TAV.7**

Documentazione senza certificazione CE  
Documentation without CE certificate

TAV.7 GRUPPO COMPRESSORE 400V 50/60HZ - 220V 60HZ TRIFASE- GROUPE COMPRESSEUR 400V 50/60HZ - 220V 60HZ TRIPHASÉ - GROUP COMPRESSOR 400V 50/60HZ - 220V 60HZ TPH - BÜSCHEL VERDICHTER 400V 50/60HZ -220V 60HZ DREIPHASIGEN- GRUPO COMPRESOR 400V 50/60HZ - 220V 60HZ TRIFASICO							
Rif.	Cod.	I	F	GB	D	E	Note
1	3226271	PIASTRA COMPONENTI	PLAQUE DE COMPRESSEUR	COMPRESSOR PLATE	VERDICHTERPLATTE	PLACA COMPRESOR	
2	3226273	SUPPORTO QUADRO ELETTRICO	SUPPORTO QUADRO ELETTRICO	SUPPORT TBLEAU ELECTRIQUE	ELECTRICAL PANNEL SUPPORT	LAGER SCHALTTAFEL	BASE CUADRO ELÉCTRICO
3	3226864	ANTIVIBRANTE	SUPPORT ANTIVIBRANTE	VIBRATION DAMPER	SCHWINGUNGS-DÄMPFER	ANTIVIBRADOR	M8X20
4	3225381	COMPRESSORE	COMPRESSEUR	COMPRESSOR	VERDICHTERPLATTE	COMPRESOR	FINI VKM 362-3 220-400V 50-60HZ 2.2Kw
5	3226885	VALVOLA DI SICUREZZA	SOUPAPE DE SOURPRESSION	RELIEF VALVE	DRUCKBREGENZUNGSVENTIL	VALVULA DE MAXIMA	M. 1/4" TIPO A5 TAR. 6BAR ISO228
6	3223618	BOCCHETTONE	EMBOUT	CAP	KAPPE	BOCA	M.F A SEDE CONICA 1/2"
7	3223607	NIPLES	NIPLES	REDUCED	NIPPLE	NIPLE	1/2" OTTONE
8	3224360	VALVOLA DI RITENUTA	SOUPAPE DE SOURPRESSION	RELIEF VALVE	DRUCKBREGENZUNGSVENTIL	VALVULA DE MAXIMA	1/2" F.F. EUROPA
9	3223617	RACCORDO "T"	RACCORD	COUPLING	VERBINDDUNGSDTCK	RACOR	"T" 1/2" F.F.F.
10	3223613	PORTAGOMMA	EMBOUT DE TUYAU AIR	HOSE CLAMP	SCHLAUCHHALTER	NIPLES	M. 1/2"X13
11	3223609	RIDUZIONE	RÉDUCTION	REDUCER	REDUZIERSTÜCK	REDUCCIÓN	M. 1/2" F.1/4" OTTONE
12	3224359	RACCORDO ARIA DIRITO	RACCORD	COUPLING	VERBINDDUNGSDTCK	RACOR	INNESTO RAPIDO 1/4" M. CONICO X TUBO 8/6"
13	3231651	PRESSOSTATO	PRESSOSTAT	PRESSURE SWITCH	DRUCHSCHALTER	PRESOSTATO	NE-MA ET12 4 VIE 6.3/10A (STEP 120 1106086 220 60Hz TPH)
13	3226865	PRESSOSTATO	PRESSOSTAT	PRESSURE SWITCH	DRUCHSCHALTER	PRESOSTATO	NE-MA ET12 4VIE 4/6.3A 2.8/4.5 BAR FIL. 1/4" (STEP 400V 50-60HZ)
14	3231666	QUADRO ELETTRICO	TBLEAU ELECTRIQUE	ELECTRICAL PANNEL	SCHALTTAFEL	CUADRO ELÉCTRICO	220V 60HZ TRIFASE TPH (1106086)
14	3231961	QUADRO ELETTRICO	TBLEAU ELECTRIQUE	ELECTRICAL PANNEL	SCHALTTAFEL	CUADRO ELÉCTRICO	400V 50/60HZ
15	3223630	PRESSOSTATO	PRESSOSTAT	PRESSURE SWITCH	DRUCHSCHALTER	PRESOSTATO	GP600 1/4" CILINDRICO 1-5 BAR
16	3225126	TAPPO OLEODINAMICO	TBLEAU ELECTRIQUE	ELECTRICAL PANNEL	SCHALTTAFEL	CUADRO ELÉCTRICO	1/4" CILINDRICO SV. 60°
17	3224345	RACCORDO ARIA 90°	RACCORD	COUPLING	VERBINDDUNGSDTCK	RACOR	GIR,INNESTO RAPIDO 1/4" CONICO X TUBO 8/6"
18	3228431	TUBO AIR WATER	TUYAU	HOSE	SCHLAUCH	MANGUERA	20 BAR 13X23 L.1300 mm
19	3225073	FASCETTA STRINGITUBO	COLLIER	CLAMP	SHELLE	ABRAZADERA	D.17-20
20	3224202	VALVOLA SFERA	BOISSEAU SPHERIQUE	BALL VALVE	KUGELVENTIL	VÁLVULA ESFERA	1/2" F.F.
21	3223957	TRONCHETTO FILETTATO	EMBOUT DE TUBE FILETE	THREADED BRANCH	GEWINDESTUTZEN	VÁSTAGO ROSCADO	M 1/2" L.85MM OTTONE
22	3224203	ATTACCO RAPIDO	RACCORD RAPIDE	QUICK CONNECTOR	SCHNELLVERBINDUNG	EMPALME RAPIDO	1/2"M.
23	3223730	GHIERA FLANGIATA	FRETTE NICKEELE	NICKEL-PLATED FLANGED RING NUTA	FLANSCHNUT VERNICKELT	VIROLA EMBRIDADA NIQUELADA	NICHELATA 1/2"
24	3224205	CURVA AMPIO RAGGIO 45°	COUDE GRAND RAYON	WIDE RADIUS BEND	GROSSE KURVE	CURVA AMPLIO RADIO	1/2" F.F.
25	3223613	PORTAGOMMA	EMBOUT DE TUYAU AIR	HOSE CLAMP	SCHLAUCHHALTER	NIPLES	M. 1/2"X13
26	3223697	GUARNIZIONE ATTACCO RAPIDO	JOINT DE RACCORD EXCENTRIQUE	QUICK COUPLING GASKET	DICHTUNG SCHNELLKUPPLER	JUNTA CONEXIÓN RÁPIDA	
27	1272701	TUBO ARIA	TUYAU	HOSE	SCHLAUCH	MANGUERA	D.8/6 L.40 mm
28	3228357	VENTOLA MOTORE	ROUBE À AUBES	FAN	ANTREIBER	IMPULSOR	
29	3228358	FILTRO COMPRESSORE	FILTRE DE COMPRESSEUR	COMPRESSOR FILTER	VERDICHTERFILTER	FILTRO COMPRESOR	

QUADRO ELETTRICO STEP 120 (3231961 400V 50/60HZ ) ( 3231666 220V 60HZ TRIFASE ) -  
TABLEAU ÉLECTRIQUE (3231961 400V 50/60HZ) (3231666 220V 60HZ TRIPHASÉ) -  
ELECTRICAL PANEL (3231961 400V 50/60HZ) ( 3231666 220V 60HZ TPH ) -  
CHALTTAFEL (3231961 400V 50/60HZ) (3231666 220V 60HZ DREIPHASIGEN ) -  
CUADRO ELÉTRICO (3231961 400V 50/60HZ) (3226166 220V 60HZ TRIFASICO)

Documentazione senza certificazione CE  
Documentation without CE certificate

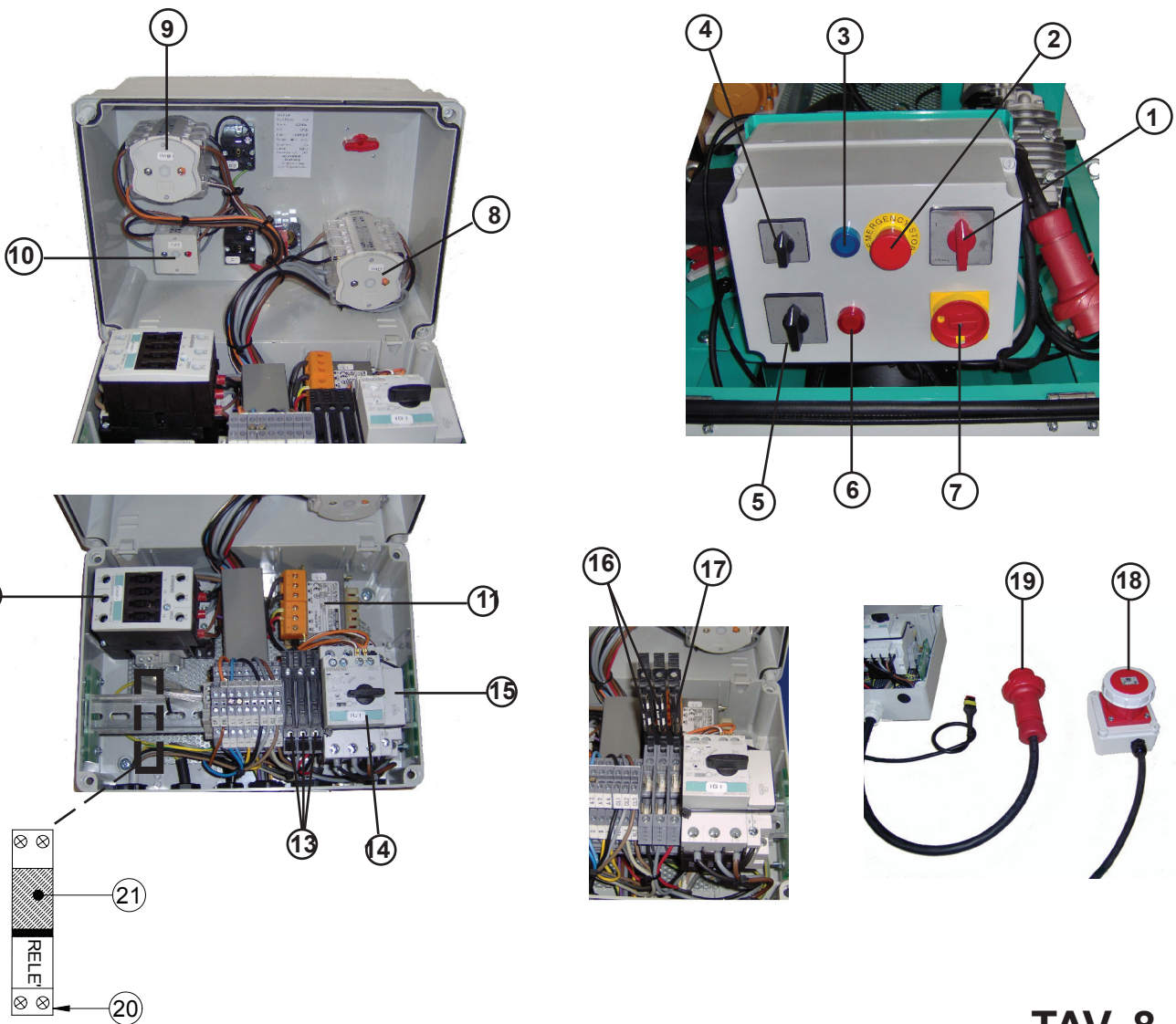

TAV. 8



<p style="text-align: center;">TAV. 8            QUADRO ELETTRICO STEP 120 (3231961 400V 50/60HZ) ( 3231666 220V 60HZ TRIFASE ) - TABLEAU ÉLECTRIQUE (3231961 400V 50/60HZ)            (3231666 220V 60HZ TRIPHASÉ) - ELECTRICAL PANEL (3231961 400V 50/60HZ) ( 3231666 220V 60HZ TPH ) - CHALTTAFEL (3231961 400V 50/60HZ)            (3231666 220V 60HZ DREIPHASIGEN) - CUADRO ELÉTRICO (3231961 400V 50/60HZ) (3226166 220V 60HZ TRIFASICO)</p>								
DA MATRICOLA: A PARTIR DU NUMÉRO DE SÉRIE: UP TO SERIAL NUMBER: VON SERIENNUMMER: DEL NÚMERO DE SERIE:	Rif.	Cod.	I	F	GB	D	E	Note
	1	3227726	MANOPOLA 1-0-2	CADRAN	GRIP HANDLE	DREHKNOPF	PERILLA	1-0-2
	2	3225237	PULSANTE STOP CON RIARMO COMPLETO	BOUTON URGENCE	EMERGENCY PUSHBOTTON	NOT-AUS-TASTER	BOTÓN EMERGENCIA	
	3	3223241	SPIA BLU COMPLETA + LAMPADA 24V	BLEUE LED COMPLETE+AMPOULE 24V	COMPLETE BLUE LED + LAMP 24V	KOMLETE BLAU LED + LAMPE 24 V	COMPLETO AZUL LED + LAMPARA 24V	
	4	3227727	MANOPOLA 0-1	CADRAN	GRIP HANDLE	DREHKNOPF	PERILLA	0-1
	5	3226837	MANOPOLA 1-0-2	CADRAN	GRIP HANDLE	DREHKNOPF	PERILLA	1-0-2
	6	3225242	SPIA ROSSA COMPLETA + LAMPADA 24V	ROUGE LED COMPLETE+AMPOULE 24V	COMPLETE RED LED + LAMP 24V	KOMLETE ROT LED + LAMPE 24 V	COMPLETO ROJO LED + LAMPARA 24V	
	7	3226345	MANOPOLA PER SALVAMOTORE	CADRAN	GRIP HANDLE	DREHKNOPF	PERILLA	0-1 64X64
	8	3227724	COMMUTATORE	COMMUTATEUR	COMMUTATOR	UMSCHALTER	CONMUTADOR	
	9	3226836	INVERTITORE DI MARCIA	INVERSEUR DE MARCHER	MARCH INVERTER	INVERTER VON MARSCH	INVERSOR DE EL MARCHAR	600V/40A 3P
	10	3227723	INTERRUTTORE	INTERRUPTEUR	SWITCH	SCHALTER	INTERRUPTOR	
3010529	11	3231962	TRASFORMATORE	TRANSFORMATEUR	TRANSFORMER	TRANSFORMATOR	TRANSFORMADOR	150VA 0-230V 400-440V
	12	3231654	CONTATTORE	CONTATTORE	CONTACTOR	KONTAKTGEBER	CONTACTOR	
	13	3227742	PORTAFUSIBILE	PORTE-FUSIBILE	FUSE HOLDER	HOLT-SCHMEZBAR FÜHREND	BASE FUSIBILE	
	14	3226109	MAGNETOTERMICO	MAGNÉOTHERMIQUE	THERMAL SWITCH	MAGNETOTHERMISCHE	MAGNETOTÉRMICO	20-25 A STEP 1106086 220V 60Hz TRIFASE-TPH
		3229069						14-20 A STEP 1106087 380V 50-60Hz
	15	3225430	BOBINA DI SGANCIO	BOBINE DE FAIRE SORTIR	COIL	SPULE	BOBINA	STEP 1106086 220V 60HZ TRIFASE-TPH
3010529	15	3225430	BOBINA DI SGANCIO	BOBINE DE FAIRE SORTIR	COIL	SPULE	BOBINA	STEP 1106087 380V 60HZ
	16	3227783	FUSIBILE	FUSIBILE	FUSE	SICHERUNG	FUSIBILE	1A 500V
	17	3227784	FUSIBILE	FUSIBILE	FUSE	SICHERUNG	FUSIBILE	4A 250V
	18	3228279	PRESA A PARETE DIR. 16A-6H-200/250V 3P+N+T 380V IP67	PRISE MURALE DIR. 16A-6H-200/250V 3P+N+T 380V IP67	STRAIGHT WALL PLUG 16A-6H-200/250V 3P+N+T 380V IP67	DIR.WANDSTECKDOSE 16A-6H-200/250V 3P+N+T 380V IP67	TOMA DE PARED DIR. 16A-6H-200/250V 3P+N+T 380V IP67	STEP 400V 50-60HZ
		3231650	PRESA 3P+T IP67 32A 200-250V 9H	PRISE MURALE DIR. 3P+T IP67 32A 200-250V 9H	STRAIGHT WALL PLUG 3P+T IP67 32A 200-250V 9H	DIR.WANDSTECKDOSE 3P+T IP67 32A 200-250V 9H	TOMA DE PARED DIR. 3P+T IP67 32A 200-250V 9H	STEP 220V 60HZ TRIFASE-TPH
	19	3231649	SPINA 3P+T 9H 32A 220V	FICHE 3P+T 9H 32A 220V	PLUG 3P+T 9H 32A 220V	WANDSTECKER 3P+T 9H 32A 220V	ENCHUFE 3P+T 9H 32A 220V	STEP 220V 60HZ TRIFASE - TPH
		2278300	SPINA 3P+T 6H 16A 380V IP67	FICHE 3P+T 6H 16A 380V IP67	PLUG 3P+T 6H 16A 380V IP67	WANDSTECKER 3P+T 6H 16A 380V IP67	ENCHUFE 3P+T 6H 16A 380V IP67	STEP 380V 50-60Hz
	20	3225274	ZOCOLO PORTA RELE'	PORTE-RELAIS	RELAY HOLDER	HOLT-RELAIS	BASE RELE'	
	21	3225228	RELE' AUSILIARIO	RELAIS	RELAY	RELAIS	RELE'	

Documentazione senza certificazione CE  
Documentation without CE certificate



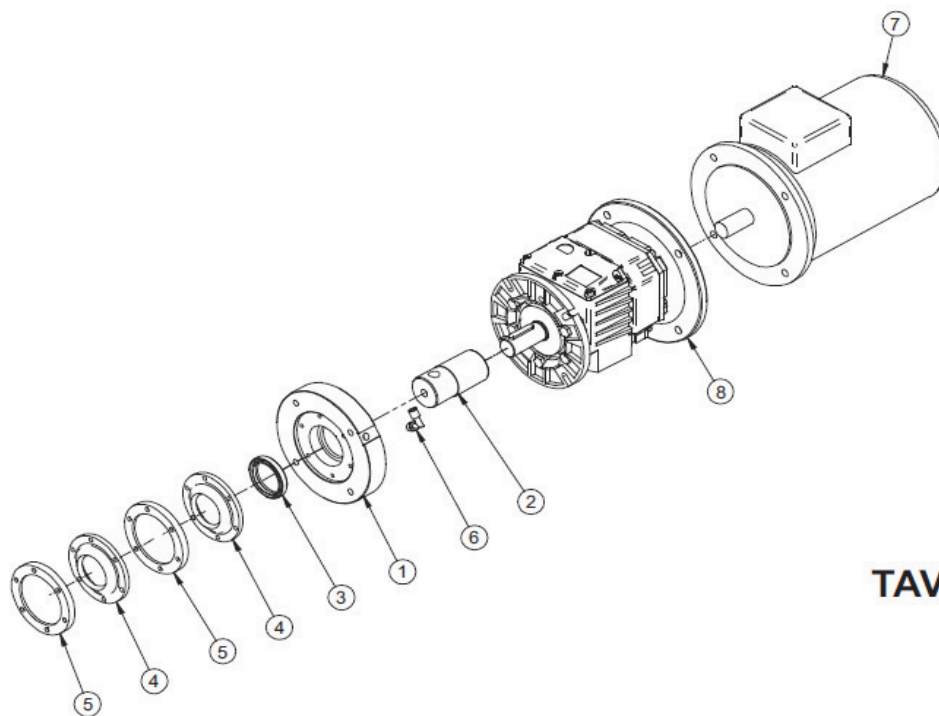

TAV.9

TAV.9 - MOTORIDUTTORE - MOTOREDUCTEUR - GEARMOTOR - GETRIEBEMOTOR - MOTOREDUCTOR							
Rif.	Cod.	I	F	GB	D	E	Note
1	3226060	FLANGIA MOTORE TRAMOGGIA	FLASQUE MOTEUR TREMIE	HOPPER MOTOR FLANGE	MOTORFLANSCH TRICHTER	BRIDA MOTOR TOLVA	
2	3224338	PROLUNGA ALBERO MOTORE	RALLONGE ARBRE MOTEUR	MOTOR SHAFT EXTENSION	VERLÄNGERUNG MOTORWELLE	PROLONGADOR EJE MOTOR	
3	3224489	ANELLO DI TENUTA	JOINT SPI	SEALING RING	DICHTRING	ANILLO DE RETENCIÓN	55x72x10
4	3224337	GUARNIZIONE DI TENUTA	JOINT D'ETANCHEITE	SEAL	DICHTUNG	JUNTA DE ESTANQUEIDAD	
5	3224311	FLANGIA GUARNIZIONI	FLASQUE JOINTS D'ETANCHEITE	SEALS FLANGE	DICHTUNGSFLANSCH	BRIDA JUNTAS	
6	3224345	RACCORDO ARIA 90°	RACCORD D'AIR 90° PIV. RACCORD RAPIDE 1/4" M	90° AIR SWIVEL QUICK COUPLING 1/4" M	DRUCKLUFT-ANSCHLUSS 90° DREHBAR SCHNEL-LKUPPLUNG 1/4" M	EMPALME AIRE 90° GIR. CONEXIÓN RÁPIDA 1/4" M	90° GIR. INN.RAPIDO1/4" M.CONICO PER TUBO 8/6"
7	3226713	MOTORE ELETTRICO 230V/400 50HZ	MOTEUR ÉLECTRIQUE 230V/400 50HZ	ELECTRIC MOTOR 230V/400 50HZ	ELEKTROMOTOR 230V/400 50HZ	MOTOR ELÉCTRICO 230V/400 50HZ	MEC 100 KW2.2 4P 230V/400 50HZ IP55
7	3231652	MOTORE ELETTRICO 220V 60HZ TRIFASE	MOTEUR ÉLECTRIQUE 220V 60HZ TRIPHASÉ	ELECTRIC MOTOR 220V 60HZ TPH	ELEKTROMOTOR 220V 60HZ DREIPHASIGEN	MOTOR ELÉCTRICO 220V 60HZ TRIFASICO	MOT.EL.T112 KW4.8/3.6 2/4P 230V/60HZ TRIF. (STEP 1106054-1106055-1106086)
7	3226712	MOTORE ELETTRICO 400V 50HZ	MOTEUR ÉLECTRIQUE 400V 50HZ	ELECTRIC MOTOR 400V 50HZ	ELEKTROMOTOR 400V 50HZ	MOTOR ELÉCTRICO 400V 50HZ	4.8/3.6KW 2-4 POLI
7	3234166	MOTORE ELETTRICO 230-400V 50/60HZ	MOTEUR ÉLECTRIQUE 230-400V 50/60HZ	ELECTRIC MOTOR 230-400V 50/60HZ	ELEKTROMOTOR 230-400V 50/60HZ	MOTOR ELÉCTRICO 230-400V 50/60HZ	KW7.5 2P 400V50HZ (STEP 120-A 1106054 - 1106094)
7	3231973	MOTORE ELETTRICO 380V 60HZ	MOTEUR ÉLECTRIQUE 380V 60HZ	ELECTRIC MOTOR 380V 60HZ	ELEKTROMOTOR 380V 60HZ	MOTOR ELÉCTRICO 380V 60HZ	5,5/4 KW 2-4P 380V 60HZ STEP 1106087
8	3226711	RIDUTTORE (PER MOTORE MONOFASE 50HZ)	RÉDUCTEUR	REDUCTION GEAR	GETRIEBE	REREDUCTOR	1106056-1106075 1106077-1106088-1106090-1106092-1106095-1106097-1106098-1106099
	3234086	RIDUTTORE (PER MOTORE TRIFASE 60HZ)	RÉDUCTEUR	REDUCTION GEAR	GETRIEBE	REREDUCTOR	1106055-1106078 1106079-1106086-1106087
	3226710	RIDUTTORE (PER MOTORE TRIFASE 50HZ) E (220/60 TPH)	RÉDUCTEUR	REDUCTION GEAR	GETRIEBE	REREDUCTOR	1106054-1106057-1106074-1106076-1106089-1106091-1106093-1106096-
	3227845	RIDUTTORE (PER MOTORE TRIFASE 50HZ)	RÉDUCTEUR	REDUCTION GEAR	GETRIEBE	REREDUCTOR	1106094 (STEP 120 A)

**VAGLIO VIBRANTE - CRIBLE - PAINTED SCREE - LACKIERTES SIEB - TAMIZ PINTADO**  
(1107592 - 230V) (1107593 - 380 V)

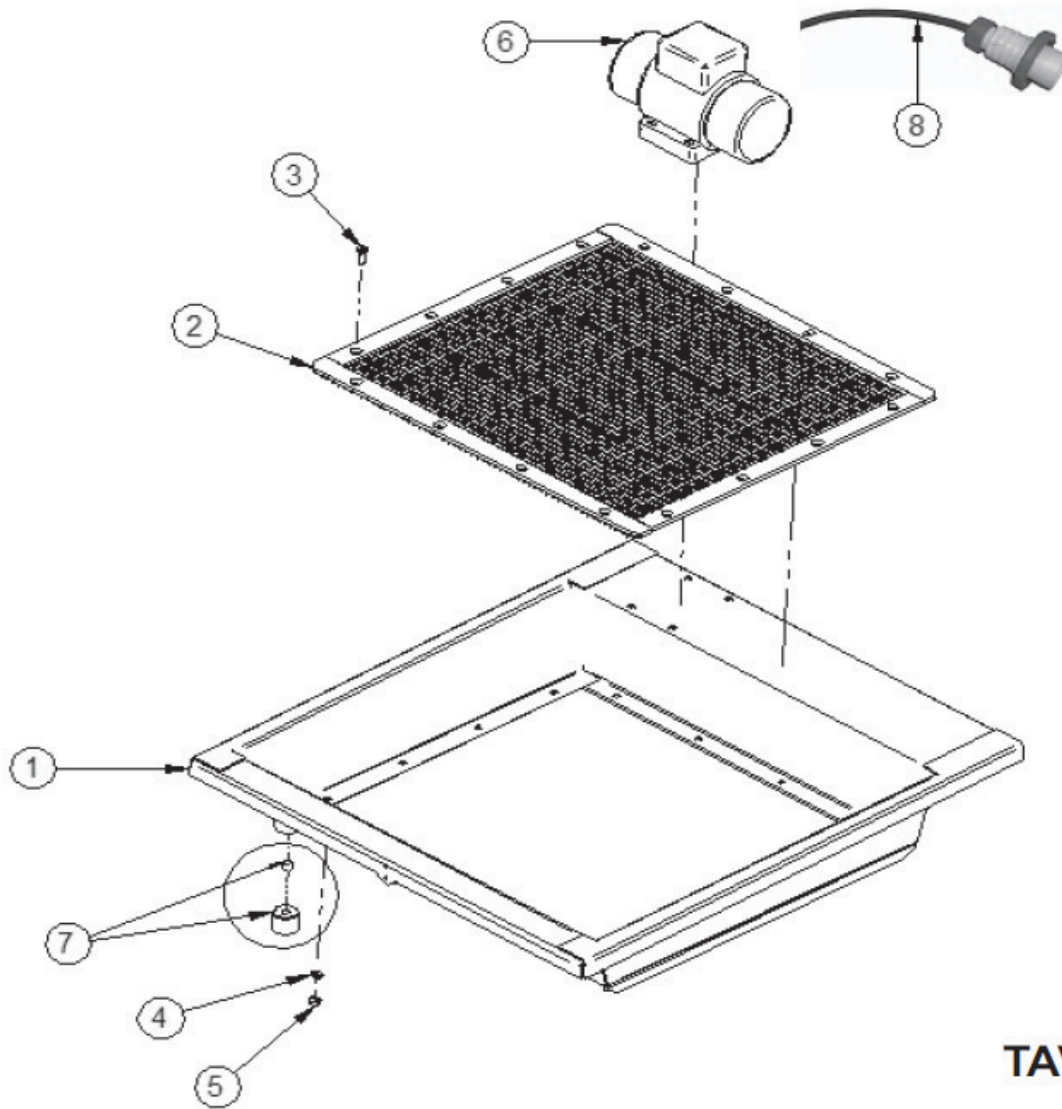

**TAV.10**

TAV.10 VAGLIO VIBRANTE - CRIBLE - PAINTED SCREE - LACKIERTES SIEB - TAMIZ PINTADO (230V - 1107592) - (380V - 1107593)							
Rif.	Cod.	I	F	GB	D	E	Note
1	3226026	VAGLIO STEP 120	CRIBLE	PAINTED SCREEN	LACKIERTES SIEB	TAMIZ PINTADO	
2	3226314	TELAIO CON RETE	CHASSIS AVEC GRILLE	FRAME WITH MESH	RAHMEN MIT NETZ	BASTIDOR CON RED	
3	3201339	VITE	VIS	SCREW	SCHRAUBE	TORNILLO	TSPEI 8.8 5933 M8X25 Z
4	1224083	RONDELLA	RONDELLE PLATE	PLAIN WASHER	FLACHE UNTER- LEGSCHIEBE	ARANDELA PLANA	UNI6593 M8 DE16X2 Z
5	3210623	DADO	ECROU AUTOBLOQUANT	SELF-LOCKING NUT	SELBSTSICHERNDE MUTTER	TUERCA AUTOBLO- QUEANTE	DIN985 M8 CLAS- SE 8
6	3226714	MOTOVIBRATORE	MOTOVIBRATEUR	MOTOR VIBRATOR	VIBRATIONSMOTOR	MOTOVIBRADOR	MVSI 3/200-S02 600312 KN2.07 RPM3000 200/400V 50HZ
7	3226027	BOCCOLA + MAGNATE	DOUILLE+AIMANTIMN	BUSCHING+MAGNETS	BUCHSE+MAGNET	BUJE+IMÁN	
8	3227361 3227360	CAVO+SPINA	CABLE ALIMENTATION	CABLE ALIMENTATION	ALIMENTATION CABLE	ERNAHRUNGKABEL	230 V 380 V

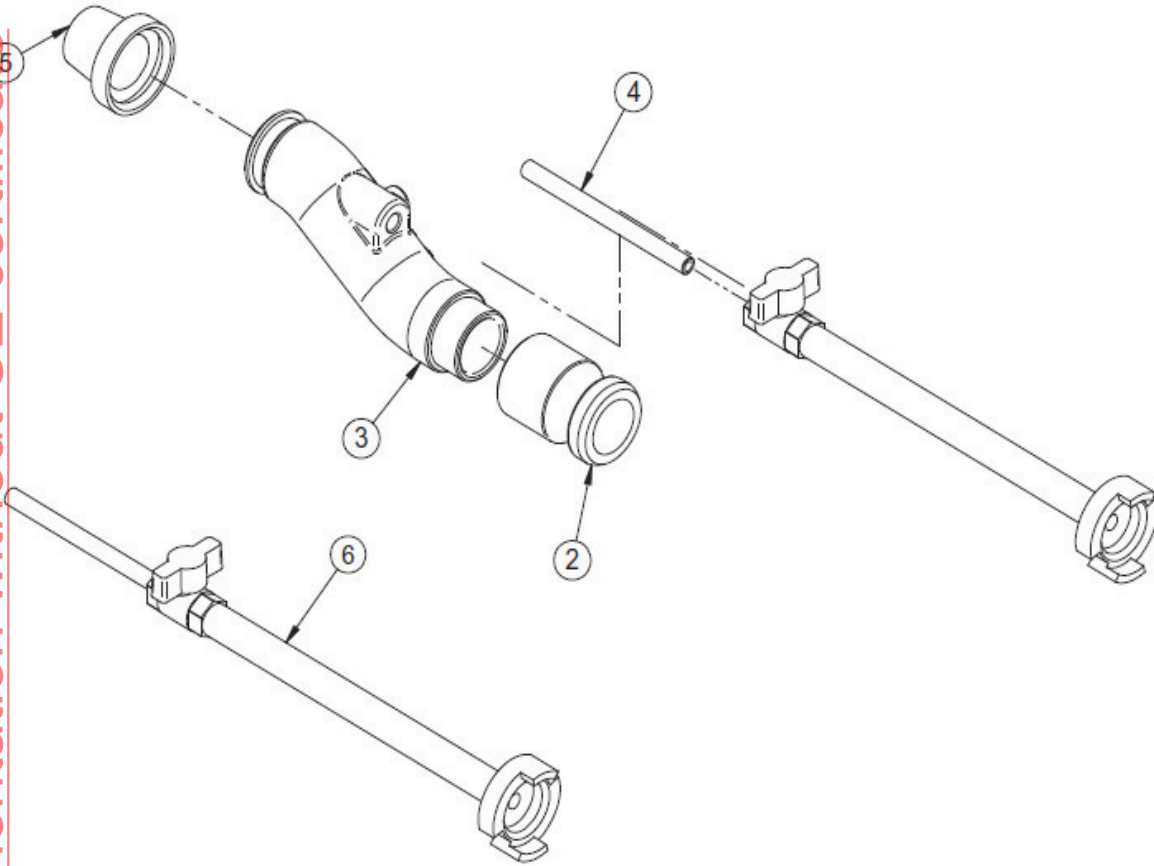
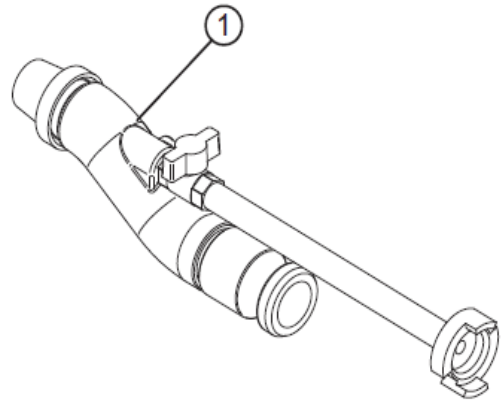

**TAV. 10.1**

TAV.10.1 LANCIA SPRUZZATRICE - LANCE DE PROJECTION - SPRAY JET - SPRUHLANZE - PISTOLA ROCIADORA							
Rif.	Cod.	I	F	GB	D	E	Note
1	1107577	LANCIA SPRUZZATRICE	LANCE DE PROJECTION	SPRAY JET	SPRUHLANZE	PISTOLA ROCIADORA	
2	3224361	ATTACCO A CAMME	RCCORD EXCENTRIQUE	CAM-LOCK COUPLING	NOCKENANSCHLUSS	RACOR TIPO CAMLOCK	DN35 M 1 1/4" G F
3	3226721	TESTA LANCIA SPRUZZATRICE	TETE DE LANCE DE PROJECTION	SPRAYER HEAD	KOPF FUR SPRITZGERAT	CABEZAL PARA LANZA ROCIADORA	D.35
4	3223350	TUBETTO ARIA ZINCATO	TUYAU D'AIR	AIR HOSE	LUFTSCHLAUCH	MANGUERA AIRE	L.135
5	1107559	KIT N°5 DEFLETTORE TRADIZIONALE D.14	KIT N°5 DêFLECTEUR TRADITIONNEL D14	KIT N°5 DEFLECTOR D14	KIT N°5 STANDARDABLEITER D14	KIT N°5 DEFLECTOR TRADITIONAL D14	D14
6	3225598	TUBO ARIA COMPLETO PER LANCIA	TUYAU D'AIR COMPLET POUR LANCE	COMPLETE HAIR HOSE FOR SPRAYER	LUFTSCHLAUCH KOMPLETT FUR SPRITZGERAT	MANGUERA AIRE COMPLETA PARA LANZA	

Documentazione senza certificazione CE  
Documentation without CE certificate

Documentazione senza certificazione CE  
Documentazione without CE certificate

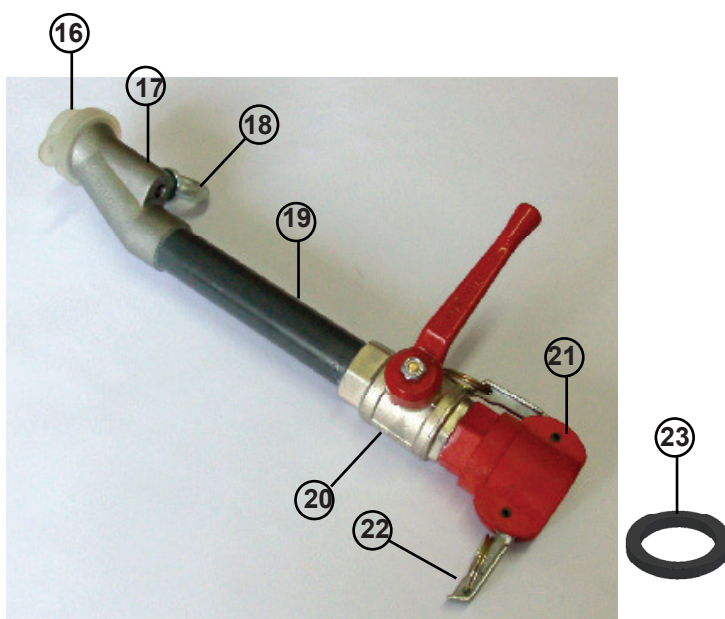
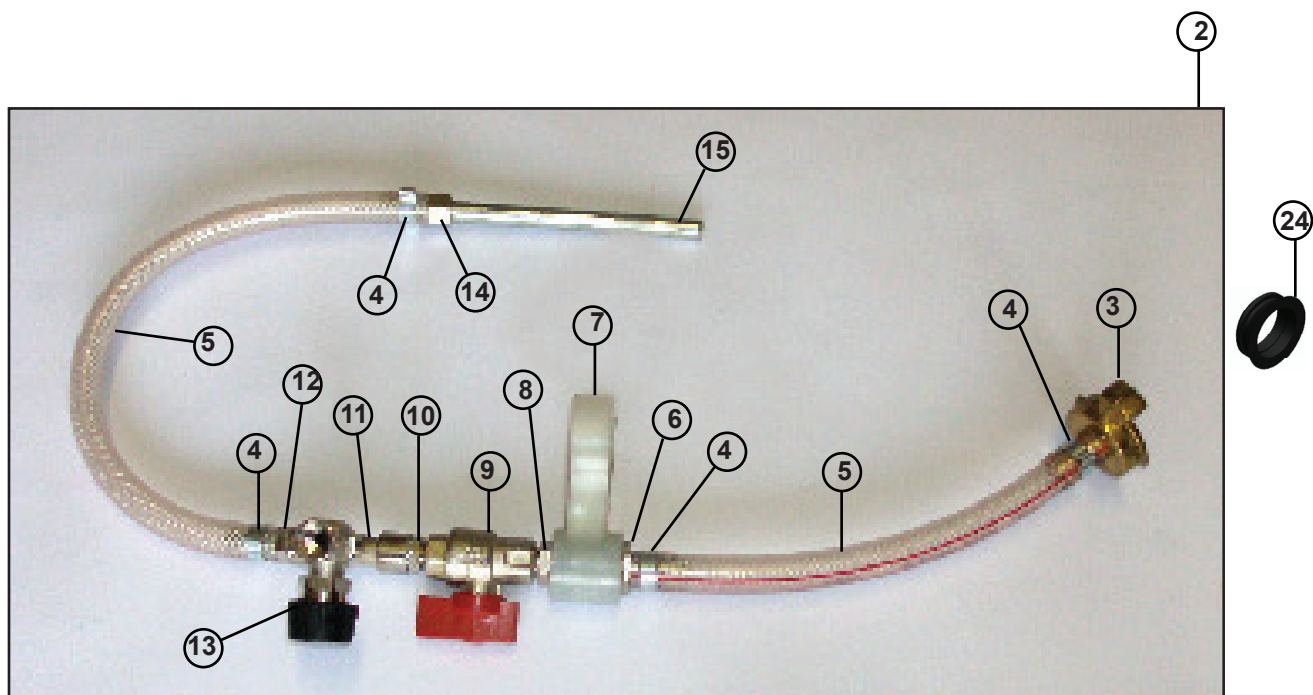

TAV. 10.2



TAV.10.2 LANCIA SPRUZZARICE - LANCE DE PROJECTION - SRPAY JET - SPRÜHLANZE - PISTOLA ROCIADORA							
Rif.	Cod.	I	F	GB	D	E	Note
1	1107568	LANCIA SPRUZZATRICE	LANCE DE PROJECTION	SRPAY JET	SPRÜHLANZE	PISTOLA ROCIADORA	
2	3225832	TUBO ARIA COMPLETO PER LANCIA	TUYAU D'AIR COMPLET POUR LANCE	COMPLETE AIR HOSE FOR SPRAYER	LUFTSCHLAUCH KOMPLETT FÜR SPRITZGERÄT	MANGUERA AIRE COMPLETA PARA LANZA	
3	3224818	ATTACCO RAPIDO	RACCORD EXCENTRIQUE	QUICK COUPLING	SCHNELLKUPPLER	CONEXIÓN RÁPIDA	D.10
4	3224823	FASCETTA STRINGITUBO	COLLIER	CLAMP	SCHELLE	ABRAZADERA	D.15-18
5	2292365	TUBO AIR WATER	TUYAU	HOSE	SCHLAUCH	MANGUERA	D.10X16
6	3228354	PORTAGOMMA	EMBOUT DE TUYAU AIR	HOSE CLAMP	SCHLAUCHHALTER	NIPLES	3/8" M. x D.10
7	3223344	RACCORDO AD ANELLO	RACCORD AVEC ANNEAU	FITTING WITH RING	ANSCHLUSSSTÜCK MIT RING	UNION CON ANILLO	3/8"
8	3228353	NIPLES RIDOTTO 3/8"-1/4"	NIPLES REDUIT 3/8"-1/4"	REDUCED NIPPLE 3/8"-1/4"	NIPPLE REDUZIERSTÜCK 3/8"-1/4"	NIPLE REDUCTOR 3/8"-1/4"	3/8"-1/4"
9	3227953	VALVOLA SFERA	BOISSEAU SPHERIQUE	BALL VALVE	KUGELVENTIL	VÁLVULA ESFERA	1/4" F.F.
10	3225186	NIPLES CONICO-CONICO	NIPPLES CONIQUE-CONIQUE	NIPPLES TAPER-TAPER	NIPPEL KEGEL-KEGEL	NIPLES CÓNICO-CÓNICO	1/4"
11	3224968	RACCORDO "T"	RACCORD	COUPLING	VERBINDUNGSDTCK	RACOR	1/4" F.F.F.
12	3224496	VALVOLA REGOLABILE	VALVE REGLABLE	VALVE ADJUSTABLE	VENTIL JUSTIERBAR	VÁLVULA AJUSTABLE	1/4" M.F.
13	3227955	PORTAGOMMA	EMBOUT DE TUYAU AIR	HOSE CLAMP	SCHLAUCHHALTER	NIPLES	1/4" M. x D.10
14	3227968	PORTAGOMMA	EMBOUT DE TUYAU AIR	HOSE CLAMP	SCHLAUCHHALTER	NIPLES	1/8" F. x D.10
15	3223350	TUBETTO ARIA ZINCATO	TUYAU D'AIR	AIR HOSE	LUFTSCHLAUCH	MANGUERA AIRE	L.135
16	1107553	KIT N°5 DUSE D.14	KIT N°5 DUSE D.14	KIT N°5 DUSE D.14	KIT N°5 DUSE D.14	KIT N°5 DUSE D.14	D.14
17	3223345	TESTA LANCIA SPRUZZATRICE	TÊTE DE LANCE DE PROJECTION	SPRAYER HEAD	KOPF FÜR SPRITZGERÄT	CABEZAL PARA LANZA ROCIADORA	
18	3209356	GOLFARE M10	VIS	SCREW	SCHRAUBE	TORNILLO	M.10
19	3223348	TUBO IN PLASTICA PER LANCIA SPRUZZATRICE	TUYAU PLASTIQUE POUR LANCE DE PROJECTION	HOSE IN PLASTIC FOR SPRAY JET	PLASTIKROHR F. SPRÜHLANZE	TUBO DE PLÁSTICO PARA PISTOLA ROCIADORA	
20	3225833	VALVOLA SFERA	BOISSEAU SPHERIQUE	BALL VALVE	KUGELVENTIL	VÁLVULA ESFERA	1" M.F.
21	3224701	ATTACCO A CAMME	RACCORD EXCENTRIQUE	CAM-LOCK COUPLING	NOCKENANSCHLUSS	RACOR TIPO CAMLOCK	DN25 F. -1" G.F.
22	3224498	LEVA	LEVIER	LEVER	HEBEL	PALANCA	DN 25-35-50
23	3224830	GUARNIZIONE ATTACCO A CAMME DN 25	JOINT DE RACCORD À CAMES DN 25	SEAL CAM COUPLING DN 25	DICHTUNG F. NOCKENANSCHLUSS DN 25	JUNTA RACOR TIPO CAMLOCK DN 25	DN.25
24	3223697	GUARNIZIONE ATTACCO RAPIDO	JOINT DE RACCORD EXCENTRIQUE	QUICK COUPLING GASKET	DICHTUNG SCHNELLKUPPLER	JUNTA CONEXIÓN RÁPIDA	

Documentazione senza certificazione CE  
Documentation without CE certificate

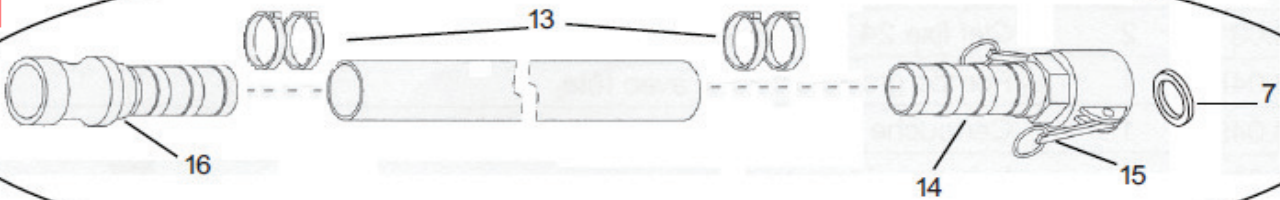
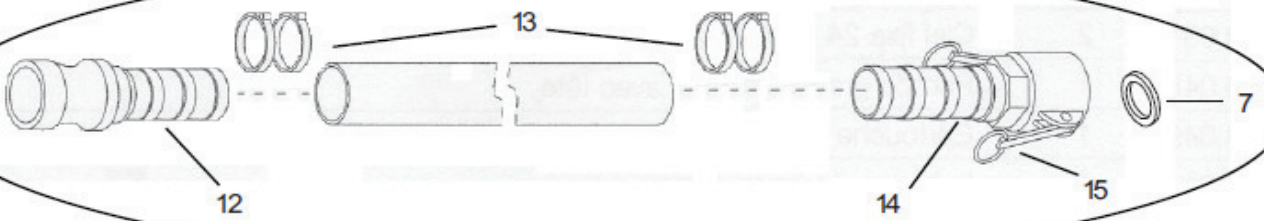
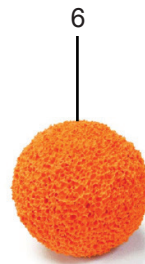
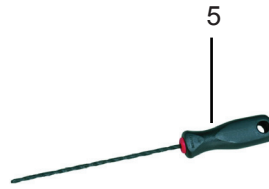

TAV.11

Documentazione senza certificazione CE  
Documentation without CE certificate

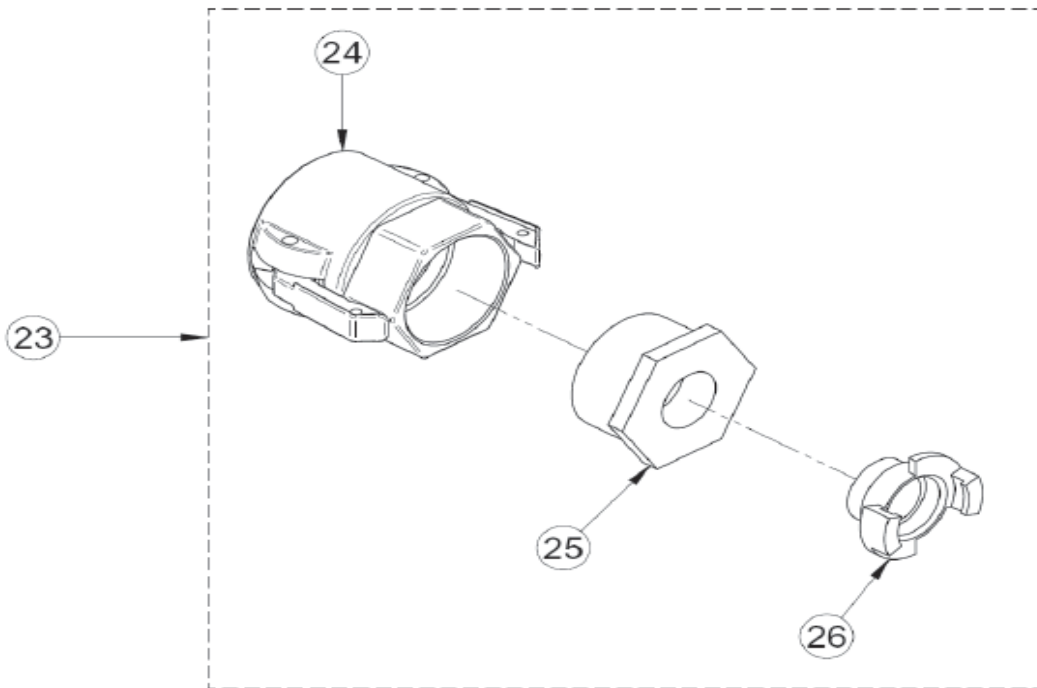
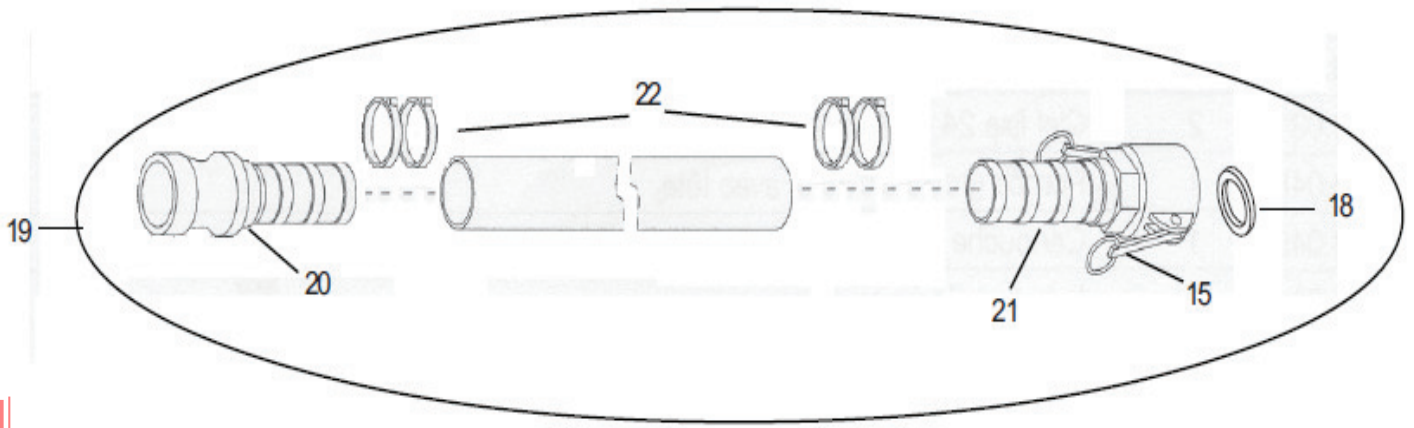

Documentazione senza certificazione CE  
Documentation without CE certificate



Documentazione senza certificazione CE

TAV11-ACCESSORI - ACCESSOIRES - ACCESSORIES - ZUBEHÖR - ACCESORIOS							
Rif.	Cod.	I	F	GB	D	E	Note
1	3224102	CASSETTA UTENSILI IN METALLO	BOITE A OUTILS METALLIQUE	METAL TOOLBOX	WERKZEUGKASTEN AUS METALL	CAJA DE METAL PARA HERRAMIENTAS	
2	3224858	POMPA GRASSO COMP. DI TUBO E TESTINA	POMPE A GRAISSE FOURNIE AVEC TUYAU ET TETE	GREASE PUMP COMP. WITH PIPE AND HEAD	FETTPUMPE KOMPL. MIT SCHLAUCH UND KOPF	BOMBA GRASA COMP. CON TUBO Y CABEZAL	
3	1107560	N°5 DEFLETTORE TRADIZIONALE 16	N°5 DÉFLECTEUR TRADITIONNEL D16	N°5 DELFECTOR D16	N°5 STANDARD-ABLEITER D16	N°5 DEFLECTOR TRADICIONAL D16	D.16
4	1107552 1107553	N°10 DUSE ø12 N°10 DUSE ø 14	N°10 DUSE ø12 N°10 DUSE ø 14	N°10 DUSE ø12 N°10 DUSE ø 14	N°10 DÜSE ø12 N°10 DÜSE ø 14	N°10 FUSIBLE ø12 N°10 FUSIBLE ø 14	D.12 D.14
5	3223694	PULITORE UGELLO D4.5	GOUPILLON DE NETTOYAGE BUSE D4.5	NOZZLE CLEANER D4.5	DÜSENREINIGER D4.5	LIMPIADOR PARA BOQUILLA D4.5	
6	1107520	N°10 SPUGNA DI LAVAGGIO D50	N°10 ÉPONGE DE LAVAGE D50	N°10 WASHING SPONGE D50	N°10 SCHWAMM D50	N°10 ESPONJA DE LAVADO D50	D.50
7	3224831	GUARNIZIONE ATTACCO A CAMME DN 35	JOINT DE RACCORD À CAMES DN 35	SEAL CAM COUPLING DN 35	DICHTUNG F. NOCKENANSCHLUSS DN 35	GUARNICIÓN RACOR TIPO CAMLOCK DN35	DN35
8	3223697	GUARNIZIONE ATTACCO RAPIDO	JOINT DE RACCORD EXCENTRIQUE	QUICK COUPLING GASKET	DICHTUNG SCHNELLKUPPLER	JUNTA CONEXIÓN RÁPIDA	
9	3224948 3225292	TUBO ARIA 10Mt TUBO ARIA 20Mt	TUBO ARIA 10Mt TUBO ARIA 20Mt	TUYAU AIR 10 Mt TUYAU AIR 20 Mt	LUFTLEITUNG 10 Mt LUFTLEITUNG 20 Mt	TUBO DE AIRE 10 Mt TUBO DE AIRE 20 Mt	L.10 Mt 13x19 L.20 Mt 13x19
10	1107075	TUBO 20Mt PORTAMATERIALE D35 CON ATTACCHI A CAMME M50/F35	TUYAU 20m DE REFOULEMENT D35 M50/F35 AVEC RACCORD EXCENTRIQUE	MATERIAL PIPE 20M D35 M50/F35 WITH CAM-LOCK COUPLINGS	MATERIALFÖRDER-SCHLAUCH (20 M) D35 M50/F35 MIT NOCKENANSCHLÜSSEN	TUBO 20 M PORTAMATERIALE D35 M50/F35 CON RACORES TIPO CAMLOCK	20 Mt
11	1107528	TUBO 10Mt PORTAMATERIALE D35 CON ATTACCHI A CAMME DN35M+DN35F.	TUYAU 10m DE REFOULEMENT D35 AVEC RACCORD EXCENTRIQUE DN35M+DN35F.	MATERIAL PIPE 10M D35 WITH CAM-LOCK COUPLINGS DN35M+DN35F.	MATERIALFÖRDER-SCHLAUCH (10 M) D35 MIT NOCKENANSCHLÜSSEN DN35M+DN35F.	TUBO 10 M PORTAMATERIALE D35 CON RACORES TIPO CAMLOCK DN35M+DN35F.	10 Mt
12	3225940	RACCORDO KAMLOCK A FASCETTARE DN 50M	RACCORD KAMLOCK A LIGATURER DN 50M	CAM-LOCK COUPLING FOR CLAMPING DN 50M	KAMLOCK-KUPPLUNG (ARRETIERUNG MITTELS SCHELLE) DN 50M	EMPALME CAMLOCK A FIJAR CON ABRAZADERA DN 50M	DN 50 M. PER TUBO DN35
13	3225943	MORSETTO STRINGITUBO	COLLIER SERRE-TUBE	PIPE CLAMP	SCHLAUCH KLEMME	MORDAZA APRIETATUBO	39+48
14	3225936	RACCORDO KAMLOCK A FASCETTARE DN 35 F	RACCORD KAMLOCK A LIGATURER DN 35 F	CAM-LOCK COUPLING FOR CLAMPING DN 35 F	KAMLOCK-KUPPLUNG (ARRETIERUNG MITTELS SCHELLE) DN 35 F	EMPALME CAMLOCK A FIJAR CON ABRAZADERA DN 35 F	DN35 F. PER TUBO DN35
15	3224498	LEVA	LEVIER	LEVER	HEBEL	PALANCA	DN 25-35-50
16	3225935	RACCORDO KAMLOCK A FASCETTARE DN 35 M	RACCORD KAMLOCK A LIGATURER DN 35 M	CAM-LOCK COUPLING FOR CLAMPING DN 35 M	KAMLOCK-KUPPLUNG (ARRETIERUNG MITTELS SCHELLE) DN 35M	EMPALME CAMLOCK A FIJAR CON ABRAZADERA DN35 M	DN 35 M. PER TUBO DN.35
17	1107521	N°10 SPUGNA DI LAVAGGIO D.60	N°10 ÉPONGE DE LAVAGE D.60	N°10 WASHING SPONGE D.60	N°10 SCHWAMM D.60	N°10 ESPONJA DE LAVADO D.60	D.60 FOR MACHINE 1106089
18	3224499	GUARNIZIONE ATTACCO A CAMME DN 50	JOINT DE RACCORD À CAMES DN 50	SEAL CAM COUPLING DN 50	DICHTUNG F. NOCKENANSCHLUSS DN 50	GUARNICIÓN RACOR TIPO CAMLOCK DN50	DN 50 FOR MACHINE 1106089
19	1107533	TUBO 10Mt PORTAMATERIALE D50 CON ATTACCHI A CAMME DN50M+DN50F.	TUYAU 10m DE REFOULEMENT D50 AVEC RACCORD EXCENTRIQUE DN50M+DN50F.	MATERIAL PIPE 10M D50 WITH CAM-LOCK COUPLINGS DN50M+DN50F.	MATERIALFÖRDER-SCHLAUCH (10 M) D50 MIT NOCKENANSCHLÜSSEN DN50M+DN50F.	TUBO 10 M PORTAMATERIALE D50 CON RACORES TIPO CAMLOCK DN50M+DN50F.	10 Mt FOR MACHINE 1106089
20	3225937	RACCORDO KAMLOCK A FASCETTARE DN 50 M	RACCORD KAMLOCK A LIGATURER DN 50 M	CAM-LOCK COUPLING FOR CLAMPING DN 50 M	KAMLOCK-KUPPLUNG (ARRETIERUNG MITTELS SCHELLE) DN 50M	EMPALME CAMLOCK A FIJAR CON ABRAZADERA DN50 M	FOR MACHINE 1106089
21	3225938	RACCORDO KAMLOCK A FASCETTARE DN 50 F	RACCORD KAMLOCK A LIGATURER DN 50 F	CAM-LOCK COUPLING FOR CLAMPING DN 50 F	KAMLOCK-KUPPLUNG (ARRETIERUNG MITTELS SCHELLE) DN 50 F	EMPALME CAMLOCK A FIJAR CON ABRAZADERA DN 50 F	FOR MACHINE 1106089
22	3225944	MORSETTO STRINGITUBO	COLLIER SERRE-TUBE	PIPE CLAMP	SCHLAUCH KLEMME	MORDAZA APRIETATUBO	60+76 FOR MACHINE 1106089
23	1107104	KIT LAVAGGIO TUBI	KIT TUYAU DE LAVAGE	KIT WASHING HOSE	TUYAU DE LAVAGE	KIT WASCHEN SCHLAUCH	FOR MACHINE 1106089
24	3224492	ATTACCO A CAMME DN50 F-2" G-F	RACCORD EXCENTRIQUE DN50 F-2" G-F	CAM-LOCK COUPLING DN50 F-2" G-F	NOCKENANSCHLUSS DN50 B-2" GAS-B	CONEXIÓN DE LEVA DN50 F-2" G-H	DN50 F-2" G F
25	3224388	RIDUZIONE M.2" F.1"	RÉDUCTION M.2" F.1"	M. REDUCTION M.2" F.1"	REDUZIERSTÜCK M.2" F.1"	REDUCCIÓN M.2" F.1"	
26	3223722	ATTACCO RAPIDO	RACCORD RAPIDE	QUICK CONNECTOR	SCHNELLVERBINDUNG	EMPALME RAPIDO	1" M.



ACCESSORI OPZIONALI - ACCESSOIRES OPTIONAL- OPTIONAL ACCESSORIES - ZUBEHÖR OPTION - ACCESORIOS OPCIÓN

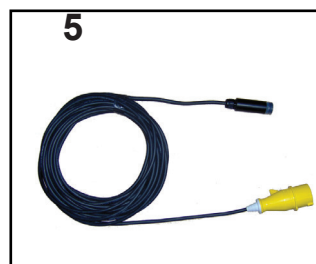
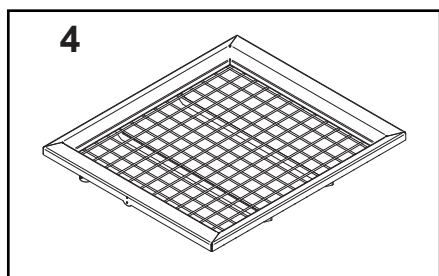
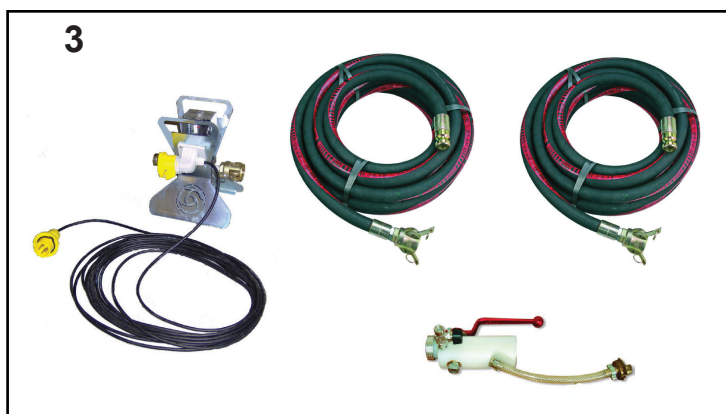
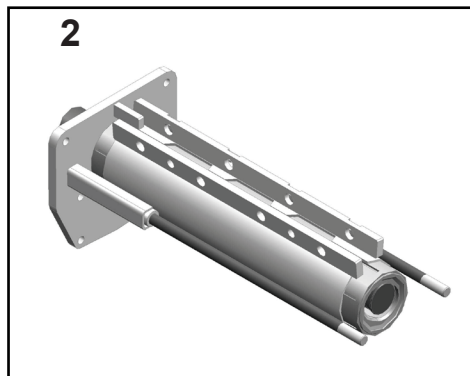
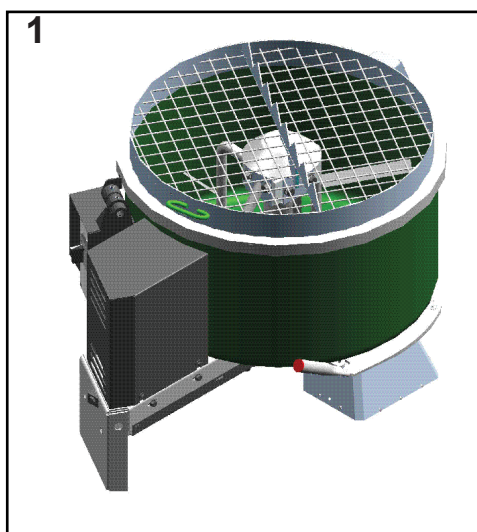

TAV.12

TAV.12 - ACCESSORI OPZIONALI - ACCESSOIRES OPTIONAL- OPTIONAL ACCESSORIES - ZUBEHÖR OPTION - ACCESORIOS OPCIÓN							
Rif.	Cod.	I	F	GB	D	E	Note
1	1107572 1107596 1107509 1107573	MESCOLATRICE 230V 50HZ MESCOLATRICE 220V 60HZ MESCOLATRICE 220V 60HZ TRIF. MESCOLATRICE 400V 50-60HZ	MALAXEUR 230V 50HZ MALAXEUR 220V 60HZ MALAXEUR 220V 60HZ TRIF. MALAXEUR 400V 50-60HZ	MIXING 230V 50HZ MIXING 220V 60HZ MIXING 220V 60HZ TPH MIXING 400V 50-60HZ	MISCHER 230V 50HZ MISCHER 220V 60HZ MISCHER 220V 60HZ TPH MISCHER 400V 50-60HZ	MEZCLADORA 230V 50HZ MEZCLADORA 220V 60HZ MEZCLADORA 220V 60HZ TRIF. MEZCLADORA 400V 50-60HZ	
2	1107088	KIT POMPA 2L6	KIT POMPE 2L6	KIT PUMP 2L6	KIT PUMPE 2L6	KIT BOMBA 2L6	2L6
3	1107594	KIT INIEZIONI	KIT INJECTIONS	INJECTION KIT	EINSPRITZSET	KIT INYECCIONES	
4	1107569	GRIGLIA PER PREMISCE- LATI	GRILLE PRÉMÉLANGÉ	PRE-MIXED FRAME	VORGEMISCHTER RAHMEN	BASTIDOR PREMEZCLADO	
5	1107574	COMANDO A DISTANZA	COMMANDE À DI- STANCE	REMOTE CONTROL	FERNSTEUERUNG	MANDO A DISTANCIA	37 Mt

TAV.14.2 (1107572 - 230V 50HZ) (1107596 - 220V 60HZ) (1107509 - 220V 60HZ TPH) (1107573 - 400V 50/60HZ)  
MESCOLATRICE - MALAXEUR - MIXING - MISCHER - MEZCLADORA  
DA MATRICOLA - FROM SERIAL NUMBER - À PARTIR DU NUMÉRO DE SÉRIE - VON SERIENNUMMER - DEL  
NÚMERO DE SERIE: 0003010074

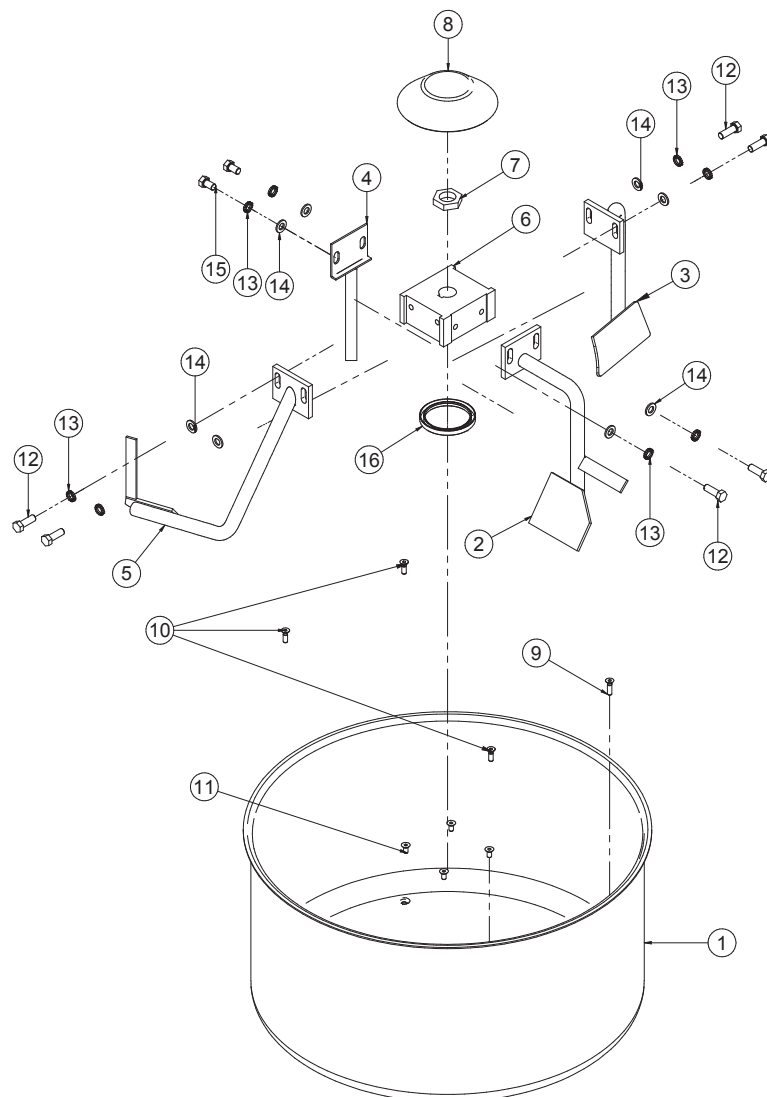

TAV.14.2

TAV.14.2 (1107572 - 230V 50HZ) (1107596 220V 60HZ) (1107509 - 220V 60HZ TPH) (1107573 - 400V 50/60HZ) MESCOLATRICE - MALAXEUR - MIXING - MISCHER - MEZCLADORA DA MATRICOLA - FROM SERIAL NUMBER - À PARTIR DU NUMÉRO DE SÉRIE - VON SERIENNUMMER - DEL NÚMERO DE SERIE: 0003010074							
Rif.	Cod.	I	F	GB	D	E	Note
1	3229602	VASCA	CUVE	TANK	TROG	RECIPIENTE	
2	3230023	PALA CENTRALE	PALETTE CENTRALE	CENTRAL PADDLE	MITTLERE SCHAUFEL	OALA CENTRAL	
3	3229594	PALA INTERNA	PALETTE INTÉRIEUR	INSIDE PADDLE	SCHAUFEL INNEN	OALA INTERNO	
4	3230013	PALA CANDELA	PALETTE	CANDLE PADLE	SCHAUFEL Zündkerze	OALA VELA	
5	3229588	PALA ESTERNA	PALETTE EXTERNA	EXTERNAL PADDLE	SCHAUFEL EXTERN	OALA EXTERNO	
6	3230009	TESTATA MESCOLATRICE	TÊ TE	HEAD	RÜHRWERKKOPF	CABEZA	
7	2223836	DADO	ECROU	NUT	MUTTER	TUERCA	5589 M30
8	3229562	COPERCHIO TESTATA					
9	3211077	VITE	VIS	SCRW	SCHRAUBE	TORNILLO	TSPEI M8X30
10	3201339	VITE	VIS	SCRW	SCHRAUBE	TORNILLO	TSPEI M8X25
11	2222586	VITE	VIS	SCRW	SCHRAUBE	TORNILLO	TSPEI 10.9 M8X16
12	2222007	VITE	VIS	SCRW	SCHRAUBE	TORNILLO	TE 5739 M12X35
13	2224900	RONDELLA	RONDELLE PLATE	PLAIN WASHER	FLACHE UNTERLEGSCHIEBE	ARANDELA PLANA	U8NI 8842 A12
14	2224380	RONDELLA	RONDELLE PLATE	PLAIN WASHER	FLACHE UNTERLEGSCHIEBE	ARANDELA PLANA	6592 12X25
15	2222034	VITE	VIS	SCREW	SCHRAUBE	TORNILLO	TE 5739 M12X20
16	2207750	ANELLO PARAOLIO	BAGUE PROTECTION HUILE	OIL SEAL RING	ÖLABASTREIFRING	ANILLO GUARDAGOTAS	100X80X10

TAV.14 (1107572 - 230V 50HZ) (1107596 - 220V 60HZ) (1107509 - 220V 60HZ TPH) (1107573 - 400V 50HZ)  
MESCOLATRICE - MALAXEUR - MIXING - MISCHER - MEZCLADORA  
DA MATRICOLA - FROM SERIAL NUMBER - À PARTIR DU NUMÉRO DE SÉRIE - VON SERIENNUMMER - DEL  
NÚMERO DE SERIE: 0003010074

Documentazione senza certificazione CE  
Documentation without CE certificate

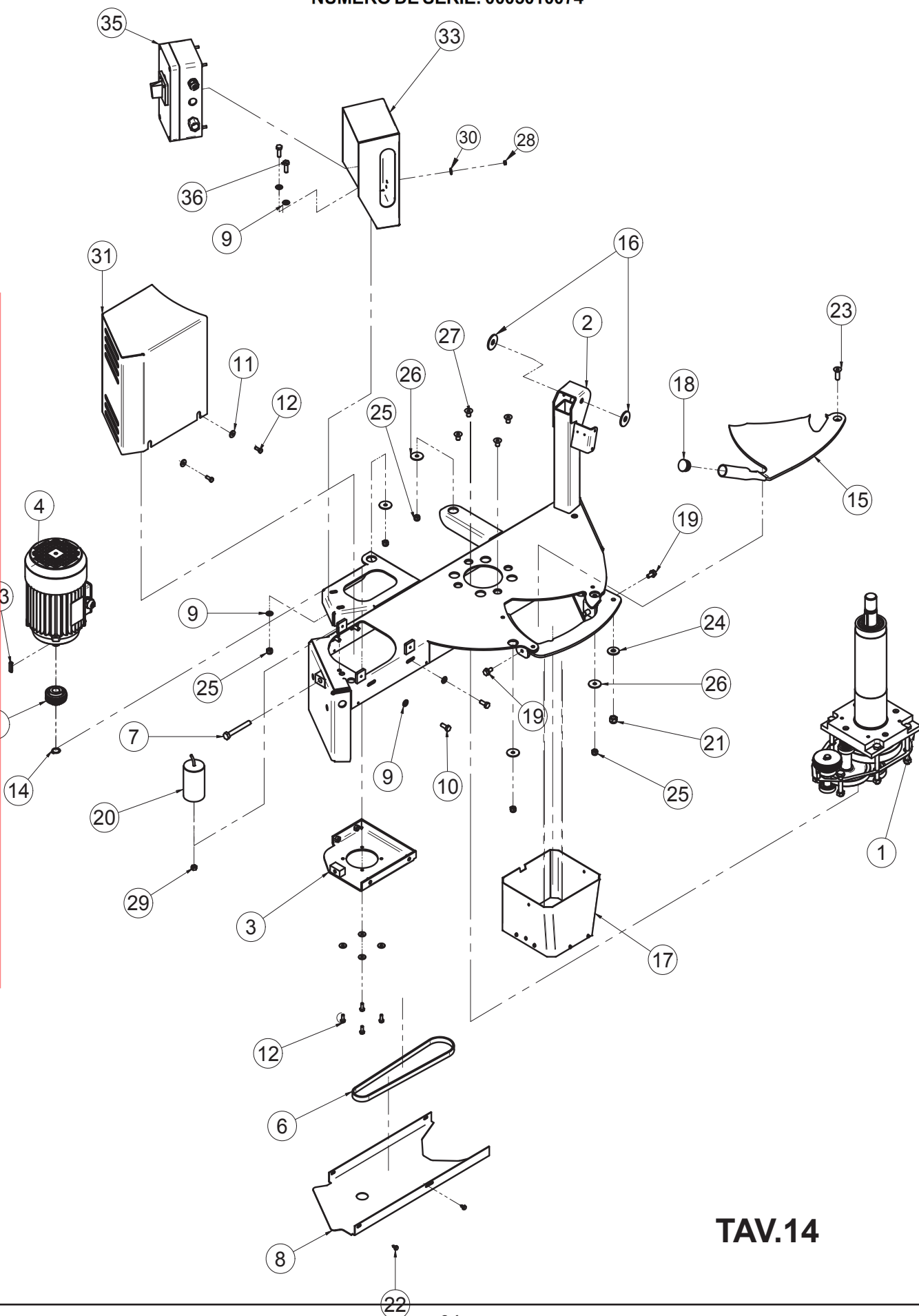

TAV.14



**TAV.14 (1107572 - 230V 50HZ) (1107596 220V 60HZ) (1107509 - 220V 60HZ TPH) (1107573 - 400V 50/60HZ)  
MESCOLATRICE - MALAXEUR - MIXING - MISCHER - MEZCLADORA  
DA MATRICOLA - FROM SERIAL NUMBER - À PARTIR DU NUMÉRO DE SÉRIE - VON SERIENNUMMER -  
DEL NÚMERO DE SERIE: 0003010074**

	Cod.	I	F	GB	D	E	Note
1	3226385	RIDUTTORE	RÉDUCTEUR	REDUCTION GEAR	GETRIEBE	REDUCTOR	
2	3231260	PONTE MESCOLATRICE					
3	3226415	SLITTA SUPPORTO MOTORE	SUPPORT MOTEUR	MOTOR SUPPORT	LAGER MOTOR	SOPORTE MOTOR	
4	3228086	MOTORE ELETTRICO	MOTEUR ÉLECTRIQUE	ELECTRIC MOTOR	ELEKTROMOTOR	MOTOR ELÉCTRICO	220V 60HZ TPH 400V 50HZ
4	3228113 3228164	MOTORE ELETTRICO MOTORE ELETTRICO	MOTEUR ÉLECTRIQUE MOTEUR ÉLECTRIQUE	ELECTRIC MOTOR ELECTRIC MOTOR	ELEKTROMOTOR ELEKTROMOTOR	MOTOR ELÉCTRICO MOTOR ELÉCTRICO	230V 50 Hz 220V 60 Hz
5	3228133	PULEGGIA	POULIE	PULLEY	SCHEIBE	POLEA	220V 50HZ 400V 50HZ
5	3229795	PULEGGIA	POULIE	PULLEY	SCHEIBE	POLEA	220V 60HZ TPH
6	3226417	CINGHIA DI TRASMISSIONE	COURROIE	DIRVING	RIEMEN	CORREA	
7	3211076	VITE	VIS	SCREW	SCHRAUBE	TORNILLO	T.E 5739 8x80
8	3228091	CARTER POTEZIONE CINGHIA	CARTER PROTECTION COURROIE	DIRVING PROTECTOR CARTER	KURBELKASTELN ARBEITSSCHUTZ RIEMEN	CÁRTER PROTECCIÓN CORREA	
9	2224140	RONDELLA	RONDELLE PLATE	PLAIN WASHER	FLACHE UNTERLEGSCHLEIBE	ARANDELA PLANA	6593 8X18
10	2222060	VITE	VIS	SCREW	SCHRAUBE	TORNILLO	T.E 5739 8X20
11	2224531	RONDELLA	RONDELLE PLATE	PLAIN WASHER	FLACHE UNTERLEGSCHLEIBE	ARANDELA PLANA	6593 6X18
12	2222002	VITE	VIS	SCRW	SCHRAUBE	TORNILLO	T.E 5739 6X16
13	2229310	LINGUETTA	LANGUETTE	KEY	FEDER	LANGUETA	6X6X30
14	2227310	ANELLO DI ARRESTO	BAGUE D'ARR T	STOP RING	ARRETIERRING	ANILLO DE PARADA	UNI 3653 E/19
15	3229559	BOCCHETTA	BOUCHE	OUTLET	BODENKLAPPE	BOCA	
16	3229622	RONDELLA	RONDELLE PLATE	PLAIN WASHER	FLACHE UNTERLEGSCHLEIBE	ARANDELA PLANA	PVC 13X40X3
17	3231875	PROTEZIONE BOCCHETTA	PROTECTION BOUCHE	OUTLET PROTECTOR	VERKLEIDUNG	PROTECCIÓN BOCA	
18	3208452	TAPPO	BOUCHIN	CAP	VERSCHLUSS	TAPÓN	GPN 320 GL 30X2
19	3227870	VITE	VIS	SCRW	SCHRAUBE	TORNILLO	TEFR TRILOB. 5739 8X16
20	3227231	CONDENSATORE	CONDENSATEUR	CAPACITOR	KONDENSATOR	CONDENSADOR	50MF 450V D.55X94 IP55 M12X10 (STEP 230V 50HZ)
	3231505	CONDENSATORE	CONDENSATEUR	CAPACITOR	KONDENSATOR	CONDENSADOR	50MF 450V 42/60HZ (STEP 220V 60HZ)
21	2223920	DADO	ECROU	NUT	MUTTER	TUERCA	7474 M10
22	2222420	VITE	VIS	SCRW	SCHRAUBE	TORNILLO	6950 4,8X13
23	2222601	VITE	VIS	SCRW	SCHRAUBE	TORNILLO	TSPEI 10.9 5933 M10X30
24	2224260	RONDELLA	RONDELLE PLATE	PLAIN WASHER	FLACHE UNTERLEGSCHLEIBE	ARANDELA PLANA	6593 10X30 SP2.5
25	2223923	DADO	ECROU	NUT	MUTTER	TUERCA	7473 M8
26	2224190	RONDELLA	RONDELLE PLATE	PLAIN WASHER	FLACHE UNTERLEGSCHLEIBE	ARANDELA PLANA	6593 8X32
27	2222605	VITE	VIS	SCRW	SCHRAUBE	TORNILLO	TSPEI 10.9 5933 M10X16
28	2223352	DADO	ECROU	NUT	MUTTER	TUERCA	5588 M5
30	2224528	RONDELLA	RONDELLE PLATE	PLAIN WASHER	FLACHE UNTERLEGSCHLEIBE	ARANDELA PLANA	6593 5X20
31	2223570	DADO	ECROU	NUT	MUTTER	TUERCA	5588 M8
32	3231275	CARTER PROTEZIONE MOTORE	CARTER PROTECTION MOTEUR	DIRVING PROTECTOR MOTOR	KURBELKASTELN ARBEITSSCHUTZ MOTOR	CÁRTER PROTECCIÓN MOTOR	
33	3234672	CARTER POTEZIONE Q.E	CARTER PROTECTION TBLEAU ELECTRIQUE	ELECTRICAL PANNEL PROTECTOR CARTER	KURBELKASTELN ARBEITSSCHUTZ	CÁRTER PROTECCIÓN CUADRO ELÉCTRICO	
35	3234666 3234667	QUADRO ELETTRICO QUADRO ELETTRICO	TBLEAU ELECTRIQUE TBLEAU ELECTRIQUE	ELECTRICAL PANNEL ELECTRICAL PANNEL	SCHALTAFEL SCHALTAFEL	CUADRO ELÉCTRICO CUADRO ELÉCTRICO	220V 380V
36	2222076	VITE	VIS	SCREW	SCHRAUBE	TORNILLO	5739 M8X25

Documentazione senza certificazione CE  
Documentation without CE certificate

**TAV.14.3 (1107572 - 230V 50HZ) (1107596- 220V 60HZ) (1107509 - 220V 60HZ TPH) (1107573 - 400V 50/60HZ)**  
**MESCOLATRICE - MALAXEUR - MIXING - MISCHER - MEZCLADORA**  
**DA MATRICOLA - FROM SERIAL NUMBER - À PARTIR DU NUMÉRO DE SÉRIE - VON SERIENNUMMER - DEL**  
**NUMÉRO DE SERIE: 0003010074**

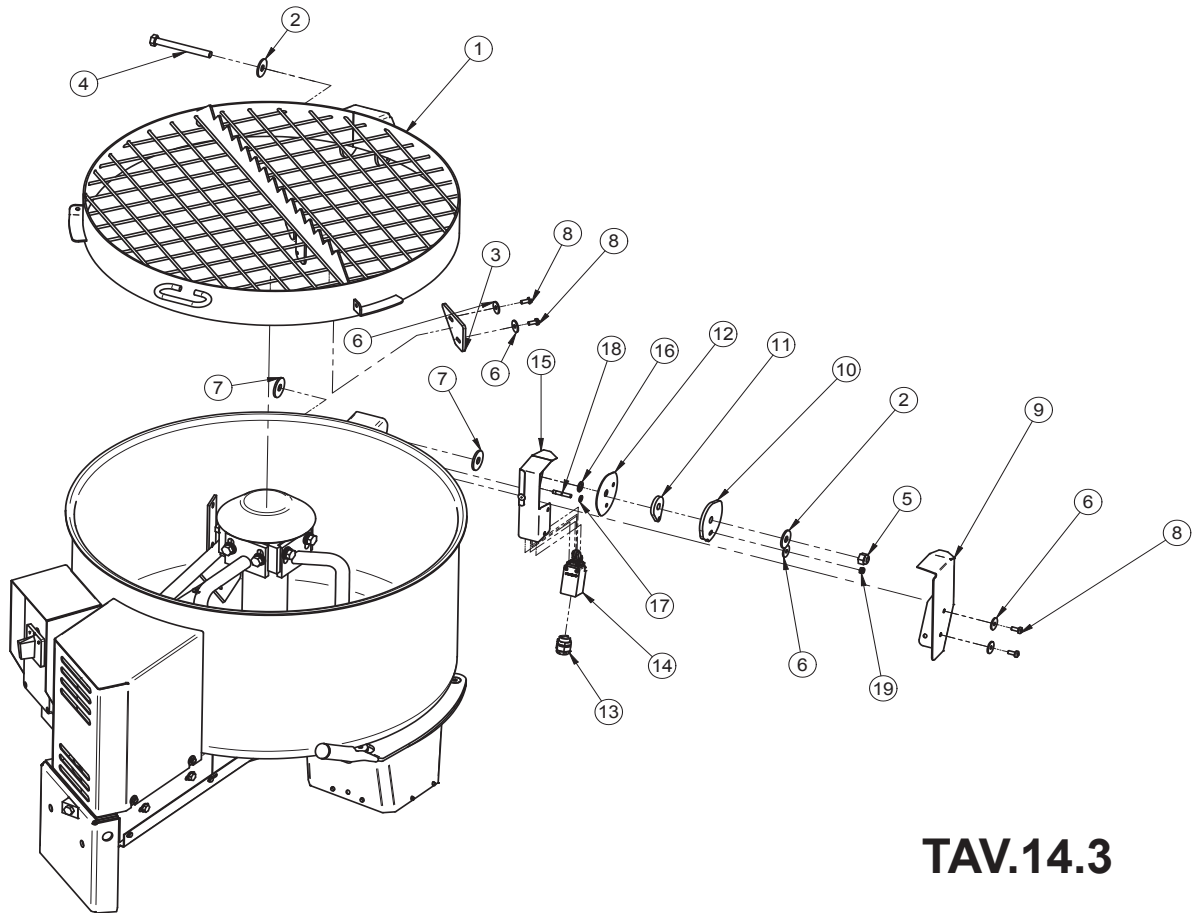

**TAV.14.3**

TAV.14.3 (1107572 - 230V 50HZ) (1107596 220V 60HZ) (1107509 - 220V 60HZ TPH) (1107573 - 400V 50/60HZ)							
MESCOLATRICE - MALAXEUR - MIXING - MISCHER - MEZCLADORA							
DA MATRICOLA - FROM SERIAL NUMBER - À PARTIR DU NUMÉRO DE SÉRIE - VON SERIENNUMMER - DEL NÚMERO DE SERIE: 0003010074							
Rif.	Cod.	I	F	GB	D	E	Note
1	3234511	PROTEZIONE MESCOLATRICE	PROTECTION CUVE	TANK PROTECTOR	TROGABDECKUNG	PROTECCIÓN RECIPIENTE	
2	3206904	RONDELLA	RONDELLE PLATE	PLAIN WASHER	FLACHE UNTERLEGSCHIEBE	ARANDELA PLANA	12X36
3	3230020	GOMMA RASCHIATORE	CAOUTCHOUC	RUBBER	GUMMIPLATTE	GOMA	
4	3206902	VITE	VIS	SCREW	SCHRAUBE	TORNILLO	TE 5737 M12X110
5	2223921	DADO	ECROU	NUT	MUTTER	TUERCA	M12
6	2224049	RONDELLA	RONDELLE PLATE	PLAIN WASHER	FLACHE UNTERLEGSCHIEBE	ARANDELA PLANA	6593 6X24
7	3229622	RONDELLA	RONDELLE PLATE	PLAIN WASHER	FLACHE UNTERLEGSCHIEBE	ARANDELA PLANA	PVC 13X40X3
8	3209728	VITE	VIS	BOLT	SCHRAUBE	TORNILLO	TRILOB.TC PH M6X15 N
9	3234820	CARTER	CARTER	CARTER	KURBELKASTEN	CÁRTER	
10	3234521	CAMMA	CAME	CAM	NOCKEN	CAM	
11	3234816	DISTANZIALE	ENTRETOISE	SPACER	ABSTANDHALTER	ESPACIADOR	
12	3234814	DISCO PROTEZIONE FINE CORSA	ENTRETOISE	SPACER PROTECTION	ABSTANDHALTER	ESPACIADOR	
13	3201216	PRESSACAVO	SERRE-CABLE	CABLE CLAMP	KABELKLEMMME	PRENSACABLE	PG. 13.5
14	3214791	FINECORSA	FIN DE COURSE	LIMIT SWITCH	ENDSCHALTER	FINAL DE CARRERA	
15	3234821	CARTER INFERIORE	CARTER INFÉRIEUR	CARTER	KURBELKASTEN NIEDRIGER	CÁRTER DESECHO	
16	3234811	RONDELLA	RONDELLE	WASHER	UNTERLEGSCHIEBE	ARANDELA	20x12.5x1.5
17	3234812	RONDELLA	RONDELLE	WASHER	UNTERLEGSCHIEBE	ARANDELA	12x6.5x1.5
18	3234822	VITE	VIS	BOLT	SCHRAUBE	TORNILLO	5909 M6x30
19	3211470	DADO	ECROU	NUT	MUTTER	TUERCA	AUTOBL. 7474 M6

TAV. 14.4- QUADRO ELETTRICO MESCOLATRICE STEP 120 - TABLEAU ÉLECTRIQUE MALAXEUR - ELECTRICAL PANEL MIXING - CHALTAFEL MISCHER - CUADRO ELÉTRICO (3231501) 230V50HZ - (3231503) 220V 60HZ TPH - 400V 50/60HZ

DA MATRICOLA - FROM SERIAL NUMBER - À PARTIR DU NUMÉRO DE SÉRIE - VON SERIENNUMMER - DEL NÚMERO DE SERIE: 0003010074

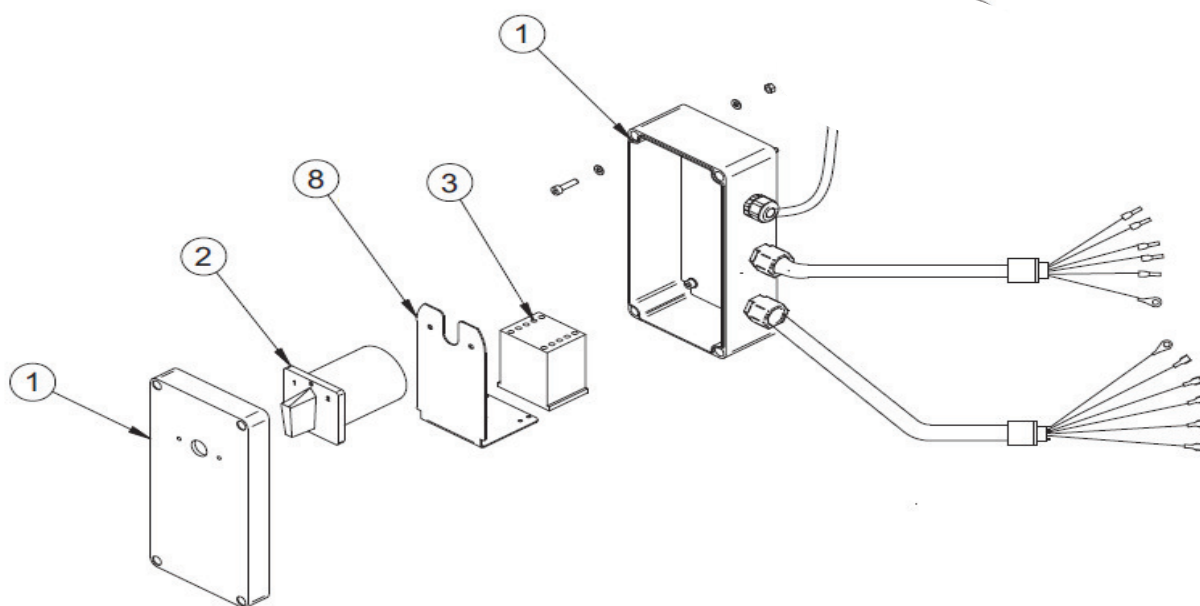

TAV. 14.4

TAV. 14.4- QUADRO ELETTRICO MESCOLATRICE STEP 120 - TABLEAU ÉLECTRIQUE MALAXEUR - ELECTRICAL PANEL MIXING - CHALTAFEL MISCHER - CUADRO ELÉTRICO (3231501) 230V50HZ - (3231503) 220V 60HZ TPH - 400V 50/60HZ DA MATRICOLA - FROM SERIAL NUMBER - À PARTIR DU NUMÉRO DE SÉRIE - VON SERIENNUMMER - DEL NÚMERO DE SERIE: 0003010074							
Rif.	Cod.	I	F	GB	D	E	Note
1	3231502	SCATOLA ELETTRICA + COPERCHIO	CAISSE ÉLECTRIQUE + COUVERCLE	ELECTRICAL BOX+COVER	ELEKTRISCH ELEKTRISCH	BOX+DECKEL ELÉCTRICO+TAPA	
2	3230075	INVERTITORE DI MARCIA	INVERSEUR DE MARCHER	MARCH INVERTER	INVERTER VON MARSCH	INVERSOR DE EL MARCHAR	1-0-2
3	3227797 3227798	CONTATTORE 230V CONTATTORE 400V	CONJONCTEUR 230V CONJONCTEUR 400V	CONTACTOR 230V CONTACTOR 400V	KONTAKTGEBER 230V KONTAKTGEBER 400V	CONTACTOR 230V CONTACTOR 400V	230V 400V
7	3230076	RESISTENZA	RÉSISTANCE	RESISTOR	WIDERSTAND	RESISTENCIA	
8	3231663	STAFFA	ÉTRIER	ÉTRIER DE FIXATION	HANGER	BÜGEL	

Documentazione senza certificazione CE  
Documentation without CE certificate

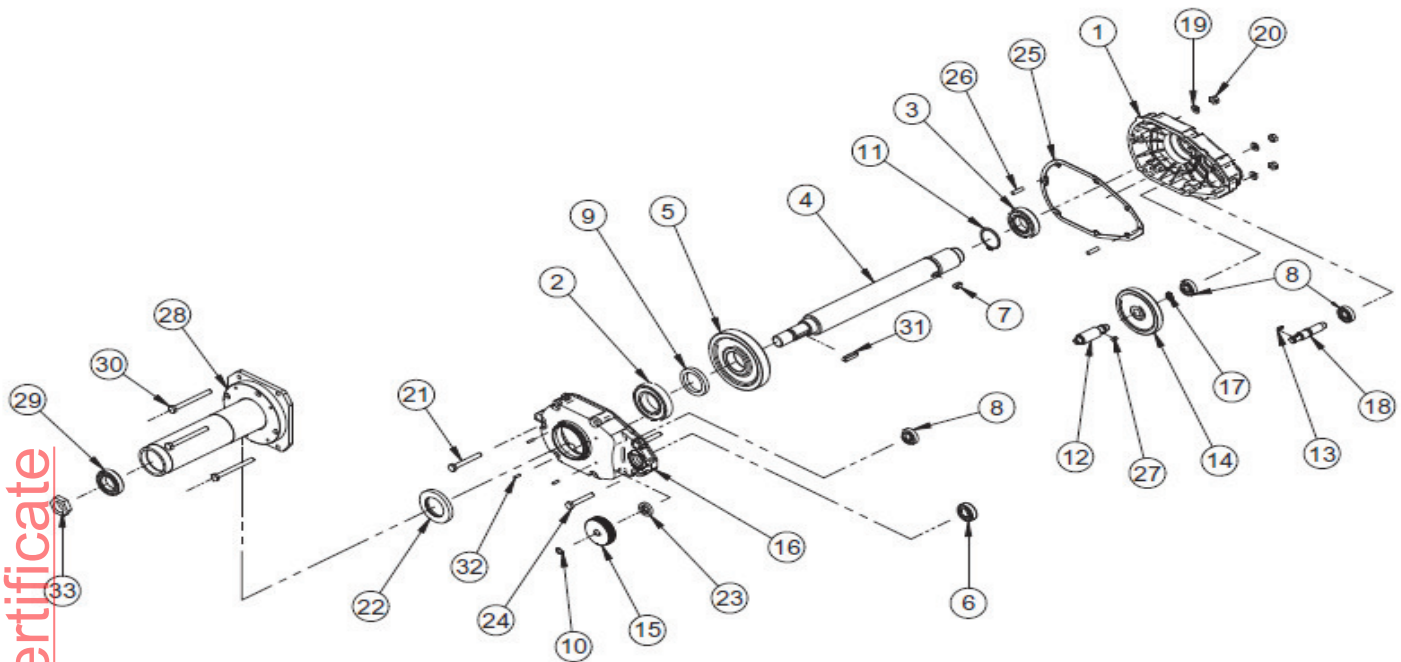

**TAV.15**

TAV.15 - RIDUTTORE MESCOLATRICE - RéDUCTEUR MALAXEUR - MIXING GEAR BOX - MISCHERGETRIEBE - REDUCTOR MEZCLADORA							
Rif.	Cod.	I	F	GB	D	E	Note
1	3209514	CARCASSA	CARCASSE	YOKE	GEHAUSE	ARMAZON	
2	2204569	CUSCINETTO	ROULEMENT	BEARING	LAGER	COJINETE	6211
3	3213282	CUSCINETTO	ROULEMENT	BEARING	LAGER	COJINETE	6208
4	3226384	ALBERO CENTRALE	ARBRE CENTRAL	MAIN SHAFT	ZENTRALANTRIEB	EJE CENTRAL	
5	3208970	INGRANAGGIO	ENGRANAGE	GEAR WHEEL	ZAHNRAD	ENGRANAJE	Z76 M2
6	3208983	CUSCINETTO	ROULEMENT	BEARING	LAGER	COJINETE	6204
7	3213178	LINGUETTA	LANGUETTE	KEY	FEDER	LENGUETA	10x8x20
8	3209682	CUSCINETTO	ROULEMENT	BEARING	LAGER	COJINETE	6302
9	3208966	DISTANZIALE	ENTRETOISE	SPACER	DISTANZRING	SEPARADOR	75x55x10
10	1227330	ANELLO DI ARRESTO	BAGUE D'ARRET	STOP RING	ARRETIERRING	ANILLO DE PARADA	3653 E/15
11	2227207	ANELLO DI ARRESTO	BAGUE D'ARRET	STOP RING	ARRETIERRING	ANILLO DE PARADA	3653 E/55
12	3208975	PIGNONE	PIGNON	PINION	RITZEL	PINON	Z11 M2
13	2229250	LINGUETTA	LANGUETTE	KEY	FEDER	LENGUETA	5x5x15
14	3209801	INGRANAGGIO	ENGRANAGE	GEAR WHEEL	ZAHNRAD	ENGRANAJE	Z79
15	3235725	PULEGGIA	POULIE	PULLEY	SCHEIBE	POLEA	D.70
16	3226386	FLANGIA RIDUTTORE	FLASQUE R&DUCTEUR	GEAR BOX FLANGE	GETRIBEFLANSCH	BRIDA REDUCTOR	
17	2227320	ANELLO DI ARRESTO	BAGUE D'ARRET	STOP RING	ARRETIERRING	ANILLO DE PARADA	7435 E/20
18	3209799	ALBERO Z10	ARBRE	SHAFT	ANTRIEB	EJE	Z10
19	2224340	RONDELLA	RONDELLE PLATE	PLAIN WASHER	FLACHE UNTERLEGSCHIEBE	ARANDELA PLANA	10x21
20	2223650	DADO	ECROU	NUT	MUTTER	TUERCA	M10
21	2222145	VITE	VIS	SCREW	SCHRAUBE	TORNILLO	VITE TE 5737 M10x80
22	3226388	ANELLO PARAOLI/POLVERE	BAGUE PROTECTION HUILE	OIL SEAL RING	OLABASTREIFRING	ANILLO GUARDAGOTAS	90x55x10
23	3200094	ANELLO PARAOLI/POLVERE	BAGUE PROTECTION HUILE	OIL SEAL RING	OLABASTREIFRING	ANILLO GUARDAGOTAS	35x20x7
24	2222148	VITE	VIS	SCREW	SCHRAUBE	TORNILLO	VITE TE 5737 M10x65
25	3209811	GUARNIZIONE FLANGIA	JOINT FLASQUE	FLANGE KASKET	FLANSCHDICHTUNG	JUNTA BRIDA	
26	3213180	SPINOTTO	FICHE	GUDGEON PIN	STIFT	PASADOR	ø8x30
27	2229259	LINGUETTA	LANGUETTE	KEY	FEDER	LENGUETA	6x6x14
28	3226390	CANDELA	BOUGIE	ADAPTOR TUBE	KERZE	BUJA	
29	2204505	CUSCINETTO	ROULEMENT	BEARING	LAGER	COJINETE	6008 2RS
30	1222694	VITE	VIS	SCREW	SCHRAUBE	TORNILLO	TE M10x10
31	2229555	LINGUETTA	LANGUETTE	KEY	FEDER	LENGUETA	
32	3226451	SPINOTTO	FICHE	GUDGEON PIN	STIFT	PASADOR	ø5x16 UNI 1707
33	2223836	DADO BASSO	ECROU	NUT	MUTTER	TUERCA	

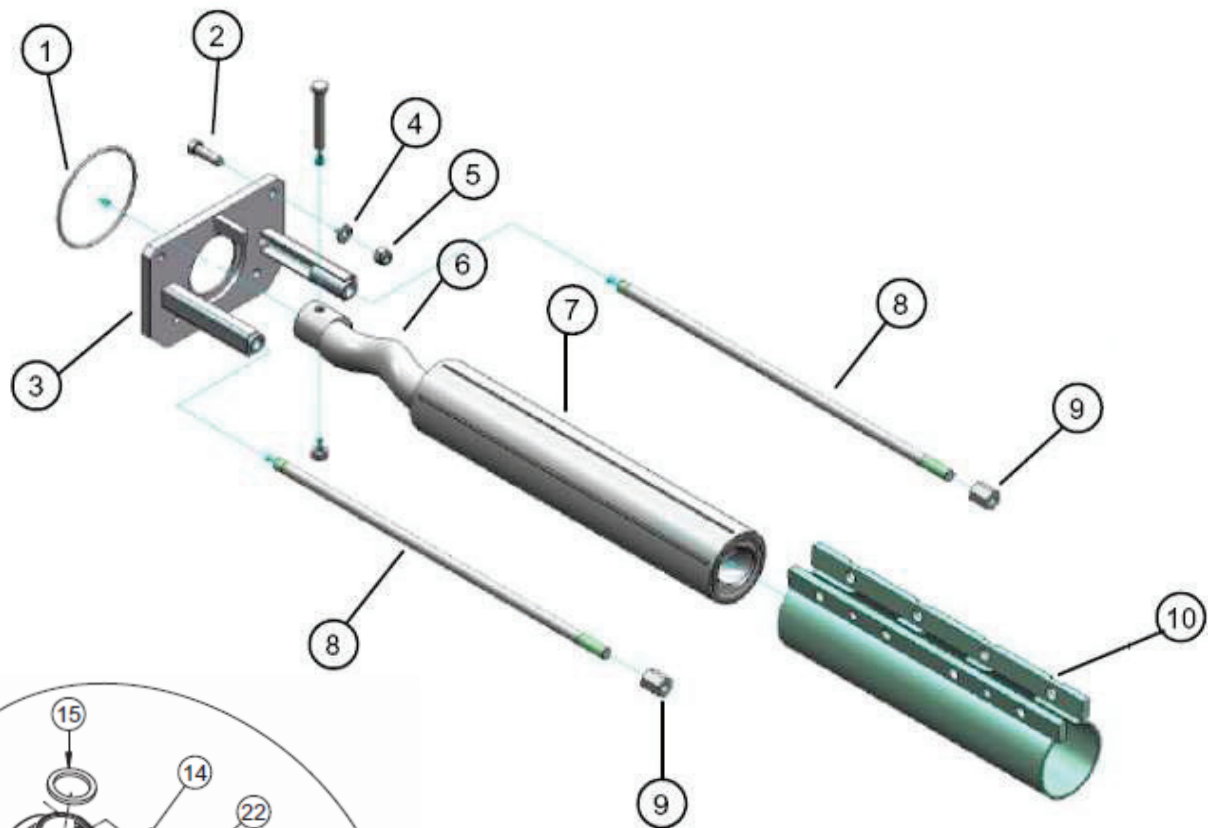

TAV.16

TAV.16 - 1107088 KIT POMPA 2L6 - KIT POMPE 2L6 - KIT PUMP 2L6 - KIT PUMPE 2L6 - KIT BOMBA 2L6

Rif.	Cod.	I	F	GB	D	E	Note
1	3224356	ANELLO OR	BAGUE	RING	RING	ANILLO	OR 4525
2	2222036	VITE	VIS	SCRW	SCHRAUBE	TORNILLO	TE M12x40
3	3224354	FLANGIA SUPPORTO VITE 2L6	FLASQUE SUPPORT DE VIS 2L6	SCREW SUPPORT FLANGE 2L6	HALTERUNGSFLANSCH SCHNECKE 2L6	BRIDA SOPORTE TORNILLO 2L6	
4	2224380	RONDELLA	RONDELLE PLATE	PLAIN WASHER	FLACHE UNTERLEGSCHNEIBE	ARANDELA PLANA	ø12x25
5	2223930	DADO	ECROU	NUT	MUTTER	TUERCA	M12
6	1107078	ROTORE 2L6	ROTOR 2L6	ROTOR 2L6	ROTOR 2L6	ROTOR 2L6	2L6
7	1107077	STATORE 2L6	STATOR 2L6	STATOR 2L6	STATOR 2L6	ESTATOR 2L6	2L6
8	3224357	TIRANTE COLLETTORE DI MANDATA 2L6	TIRANT DE COLLECTEUR DE REFOULEMENT2L6	DELIVERY MANIFOLD STAY 2L6	VERSTREBUNG DRUCKSEITIGE SAMMELLEITUNG2L6	TIRANTE COLECTOR DE IMPULSIÓN 2L6	
9	3224395	DADO M16 SPECIALE	ECROU SPECIAL	SPECIAL NUT	SPEZIALMUTTER	TUERCA ESPECIAL	
10	3224334	STRETTORE VITE	SERRE JAQUETTE	SCREW CLAMP	DROSSELSTÜCK SCHNECKE	APREDATOR TORNILLO	
11	3228329	COLLETTORE DI MANDATA COMPLETO	COLLECTEUR DE REFOULEMENT COMPLET	DELIVERY MANIFOLD COMPLETE	DRUCKSEITIGE SAMMELLEITUNG COMPLETE	COLECTOR DE IMPULSIÓN COMPLETO	
12	3224492	ATTACCO A CAMME DN50 F-2" G-F	RACCORD EXENTRIQUE DN50 F-2" G-F	CAM-LOCK COUPLING DN50 F-2" G-F	NOCKENANSCHLUSS DN50 B-2" GAS-B	CONEXIÓN DE LEVA DN50 F-2" G-H	DN50 F-2" G F
13	3224390	COLLETTORE DI MANDATA	COLLECTEUR DE REFOULEMENT	DELIVERY MANIFOLD	DRUCKSEITIGE SAMMELLEITUNG	COLECTOR DE IMPULSIÓN	
14	3224498	LEVA ATTACCO A CAMME	LEVIER	LEVER	HEBEL	PALANCA	DN 25-35-50
15	3224499	GUARNIZIONE ATTACCO A CAMME DN 50	JOINT DE RACCORD À CAMES DN 50	SEAL CAM COUPLING DN 50	DICHTUNG F. NOCKENANSCHLUSS DN 50	GUARNICIÓN RACOR TIPO CAMLOCK DN 50	DN50
16	3226640	SPINA	GOUJON	PIN	STIFT	CHAVETA	



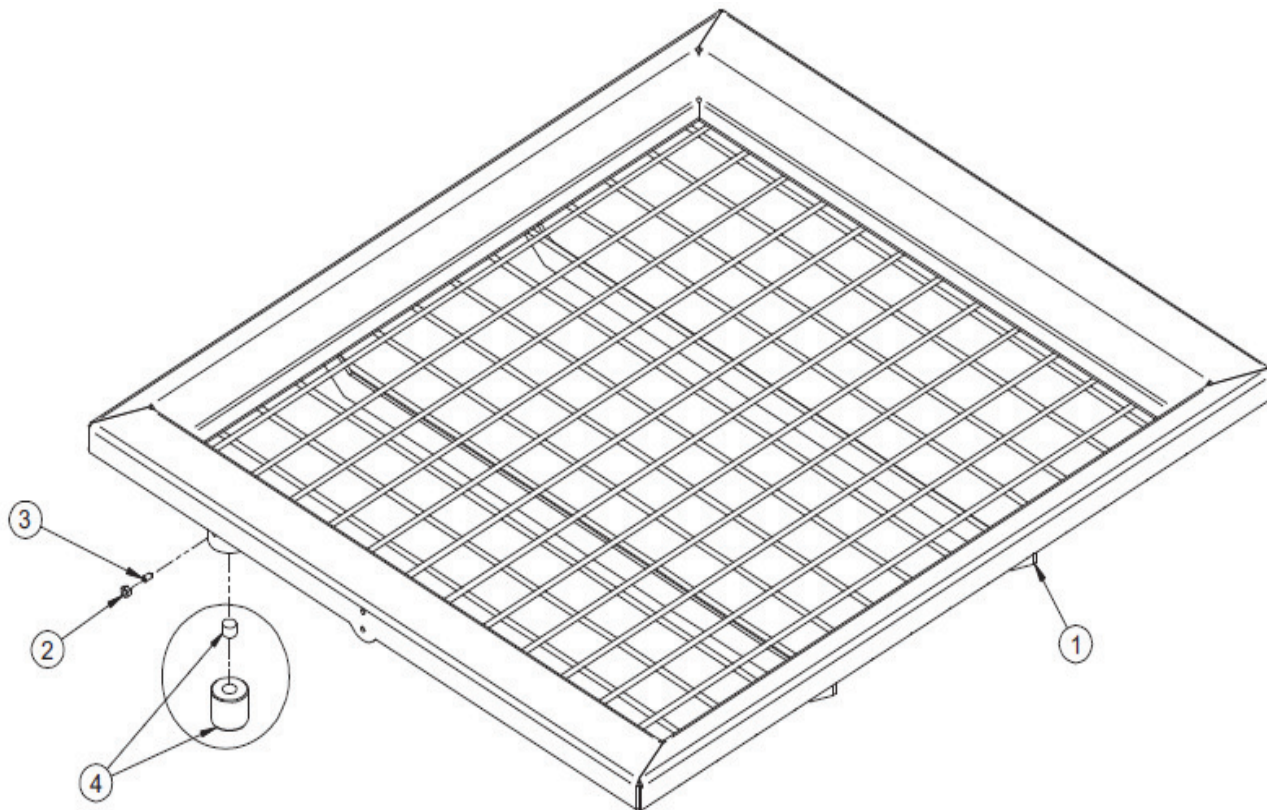

**TAV.18**

TAV.18 - 1107569 GRIGLIA PER PREMISCELATI - 1107569 GRILLE PR&M&LANG& - 1107569 PRE-MIXED FRAME - 1107569 VORGEMISCHTER RAHMEN - 1107569 BASTIDOR PREMEZCLADO							
Rif.	Cod.	I	F	GB	D	E	Note
1	3226321	RETE DI SICUREZZA	GRILLE	FRAME	RAHMEN	BASTIDOR	
2	2223352	DADO	ECROU AUTOBLOQUANT	SELF-LOCKING NUT	SELBSTSICHERNDE MUTTER	TUERCA AUTOBLOQUEANTE	UNI-5588 M5 CLASSE8
3	3225175	VITE	VIS	SCREW	SCHRAUBE	TORNILLO	UNI5927 M5X10 Z
4	3226027	BOCCOLA+MAGNETE	DOUILLE+AIMANTIMN	BUSCHING+MAGNETS	BUCHSE+MAGNET	BUJE+IMAN	

Documentazione senza certificazione CE  
Documentazione without CE certificate

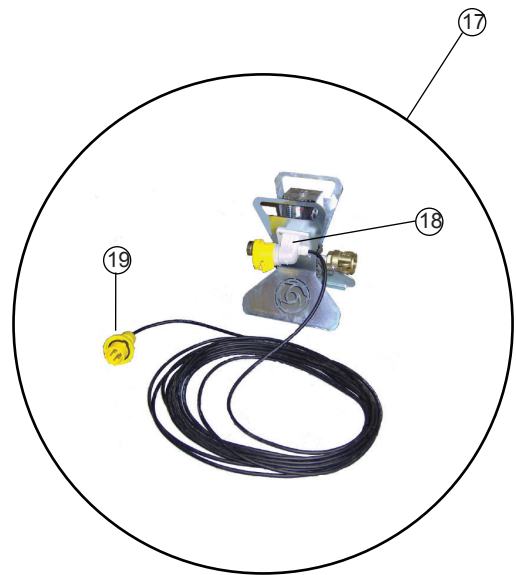
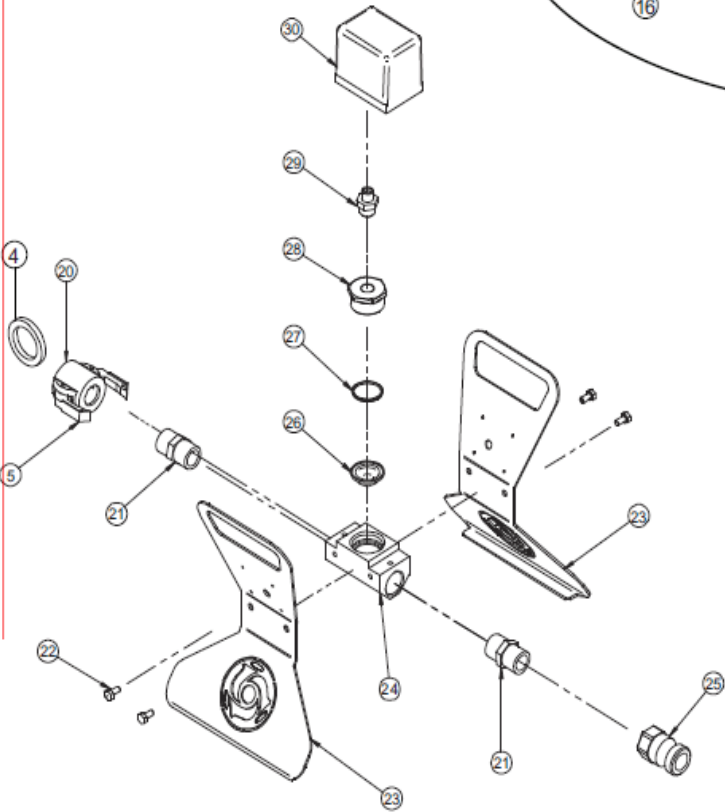
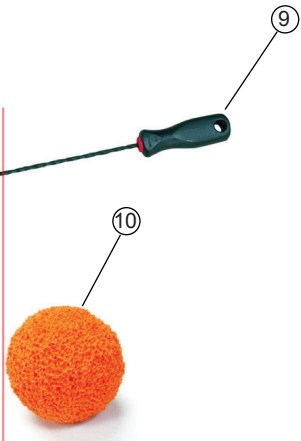
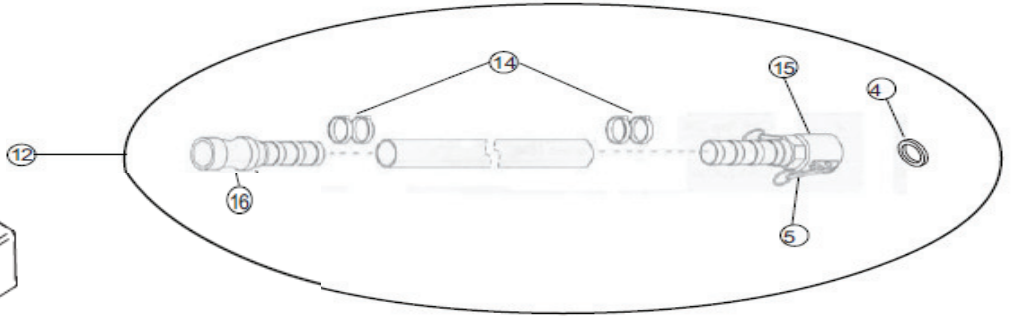
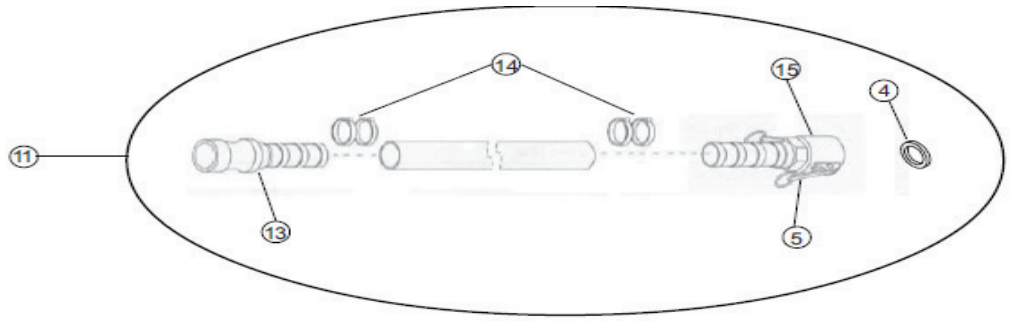
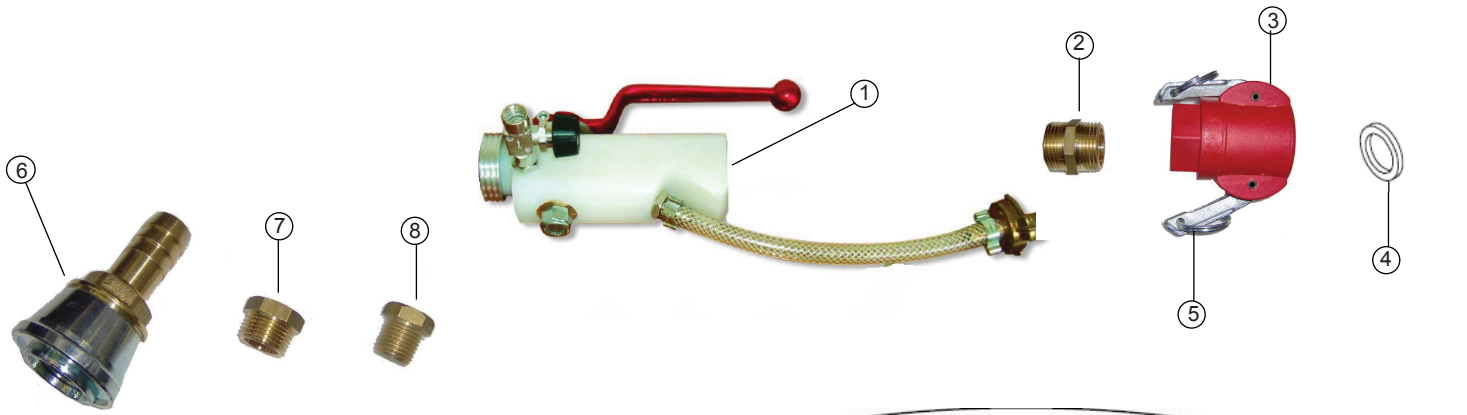

TAV.17

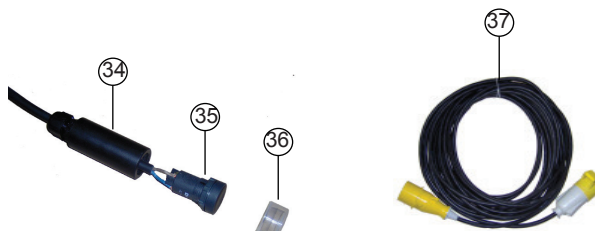
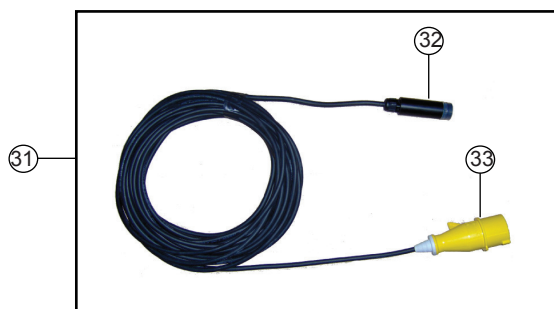

## TAV.17

RIF.	CODE	I	F	GB	D	E	Note
1	3224301	LANCIA SPRUZZATRICE PER RASANTI FUGHE E INIEZIONI	LANCE DE PROJECTION POUR PRODUITS DE RAGRÉAGE, JOINTOIEMENT E INJECTIONS	IISPRAY JET FOR LEVELLERS, GROUT AND INJECTIONS	SPRÜHLANZE FÜR KRATZPUTZ FUGENMATERIAL UND EINSPRITZUNGEN	PISTOLA ROCIADORA PARA NIVELANTES JUNTAS E INYECCIONES	
2	3224956	NIPLES 1" OTTONE	NIPLES 1" LAITON	NIPPLES 1" BRASS	MESSINGNIPPEL 1"	NIPLES 1" LATÓN	
3	3224701	ATTACCO A CAMME DN25 F1"G F PLAST. BETON.	RACCORD À CAMES DN25 F1"G F PLAST. BETON.	CAM COUPLING DN25 F1"G F PLAST.	NOCKENANSCHLUSS DN25 F1"G F PLAST. BETON.	RACOR TIPO CAMLOCK DN25 F1"G H PLÁST. MEZCLADORA	
4	3224830	GUARNIZIONE ATTACCO A CAMME DN 25	JOINT DE RACCORD À CAMES DN 25	SEAL CAM COUPLING DN 25	DICHTUNG F. NOCKENANSCHLUSS DN 25	GUARNICIÓN RACOR TIPO CAMLOCK DN 25	DN 25
5	3224498	LEVA	LEVIER	LEVER	HEBEL	PALANCA	DN 25-35-50
6	1107566	N°3 DEFLETTORE CON PORTAGOMMA D16 SMALL 50	N°3 DÉFLECTEUR AVEC EMBOUT DE TUYAU AIR D16 SMALL 50	N°3 DEFLECTOR WITH HOSE CLAMP D16 SMALL 50M	N°3 ABLEITER MIT GUMMIHALTER D16 SMALL 50	N°3 DEFLECTOR CON ADAPTADOR16 SMALL 50	
7	3223612	TAPPO FILETTATO M.3/8"	BOUCHON FILETÉ M.3/8"	THREADED PLUG M.3/8"	GEWINDEVERSCHLUSS M.3/8"	TAPÓN ROSCADO M. 3/8"	
8	3224967	TAPPO FILETTATO M.1/4"	BOUCHON FILETÉ M.1/4"	THREADED PLUG M.1/4"	GEWINDEVERSCHLUSS M.1/4"	TAPÓN ROSCADO M. 1/4"	
9	3223694	PULITORE UGELLO D4.5	GOUPILLON DE NETTOYAGE DE BUSE D4.5	NOZZLE CLEANER D4.5	DÜSENREINIGER D4.5	LIMPIADOR BOQUILLA D4.5	
10	1107519	N°10 SPUGNA DI LAVAGGIO D30	N°10 ÉPONGE DE LAVAGE D30	N°10 WASHING SPONGED30	N°10 SCHWAMM D30	N°10 ESPONJA DE LAVADO D30	
11	1107527	TUBO 5m PORTAMATERIALE D25 CON ATTACCHI A CAMME DN25 M+DN25 F.	TUYAU 5 m EMBOUT DE TUYAU PRODUIT D25 AVEC RACCORDS À CAMES DN25 M+DN25 F.	5m MATERIAL CARRIER HOSE D25 WITH CAM COUPLINGS DN25 M+DN25 F.	MATERIA-FÖRDERLEITUNG 5m D25 MIT NOCKENANSCHLÜSSEN DN25 M+DN25 F.	TUBO PORTAMATERIALE 5 m D25 CON RACORES TIPO CAMLOCK DN25 M+DN25 F.	5Mt Ø 25 DN27 M.+DN27 F.
12	1107074	TUBO 5m PORTAMATERIALE D25 CON ATTACCHI A CAMME DN35 M+DN25 F.	TUYAU 5 m EMBOUT DE TUYAU PRODUIT D25 AVEC RACCORDS À CAMES DN35 M+DN25 F.	5m MATERIAL CARRIER HOSE D25 WITH CAM COUPLINGS DN35 M+DN25 F.	MATERIA-FÖRDERLEITUNG 5m D25 MIT NOCKENANSCHLÜSSEN DN35 M+DN25 F.	TUBO PORTAMATERIALE 5 m D25 CON RACORES TIPO CAMLOCK DN35 M+DN25 F.	5Mt Ø 25 DN35 M.+DN27 F.
13	3225933	RACCORDO KAMLOCK A FASCETTARE DN 27 M	RACCORD KAMLOCK A LIGATURER DN 27 M	CAM-LOCK COUPLING FOR CLAMPING DN 27 M	KAMLOCK-KUPPLUNG (ARRETIERUNG MITTELS SCHELLE) DN 27 M	EMPALME CAMLOCK A FIJAR CON ABRAZADERA DN27 M	DN 27 M.PER TUBO DN.25
14	3225942	MORSETTO STRINGITUBO	COLLIER SERRE-TUBE	PIPE CLAMP	SCHLAUCH KLEMMME	MORDAZA APRIETATUBO	32+40 PER TUBO 25x3
15	3225933	RACCORDO KAMLOCK A FASCETTARE DN 25M	RACCORD KAMLOCK A LIGATURER DN 25M	CAM-LOCK COUPLING FOR CLAMPING DN 25M	KAMLOCK-KUPPLUNG (ARRETIERUNG MITTELS SCHELLE) DN 25M	EMPALME CAMLOCK A FIJAR CON ABRAZADERA DN25 M	DN 27 M.PER TUBO DN.25
16	3225939	RACCORDO KAMLOCK A FASCETTARE DN 35M	RACCORD KAMLOCK A LIGATURER DN 35M	CAM-LOCK COUPLING FOR CLAMPING DN 35M	KAMLOCK-KUPPLUNG (ARRETIERUNG MITTELS SCHELLE) DN 35M	EMPALME CAMLOCK A FIJAR CON ABRAZADERA DN35M	DN 35 M. PER TUBO DN.25
17	1107515	DISPOSITIVO INIEZIONI	DISPOSITIF INJECTIONS	INJECTION DEVICE	EINSPRITZS APPARAT	DISPOSITIVO INYECCIONES	
18	3224769	PRESA A PARETE 90°16A 4H 100/130V 3P+T IP67	PRISE MURALE 90°16A 4H 100/130V 3P+T IP67	STRAIGHT WALL PLUG 90°16A 4H 100/130V 3P+T IP67	WANDSTECKDOSE 90°16A 4H 100/130V 3P+T IP67	TOMA DE PARED 90°16A 4H 100/130V 3P+T IP67	
19	3226541	SPINA 3P+T 110V 16A IP67	FICHE 3P+T 110V 16A IP67	PLUG 3P+T 110V 16A IP67	WANDSTECKER 3P+T 110V 16A IP67	ENCHUFE DE 3P+T 110V 16A IP67	
20	3224709	ATTACCO A CAMME D.25 F-1" G F	RACCORD À CAMES D.25 F-1" G F	CAM COUPLING D.25 F-1" G F	NOCKENANSCHLUSS D.25 F-1" G F	RACOR TIPO CAMLOCK D.25 H-1" G H	
21	3224353	NIPLES 1"	NIPLES 1"	NIPPLES 1"	NIPPEL 1"	NIPLES 1"	
22	2222064	VITE TE M 8X16 Z	VIS TH M 8X16 Z	TE SCREW M 8X16 Z	SECHSKANTSCHRAUBE M 8X16 Z	TORNILLO TE M 8X16 Z	
23	3224765	LAMIERA APPOGGIO MISURATORE PRESSIONE	TÔLE D'APPUI MESUREUR DE PRESSION	PRESS GAUGE SUPPORT PLATE	AUFLAGEBLECH F. DRUCKMESSER	CHAPA APOYO MEDIDOR PRESIÓN	
24	3224762	BLOCCHETTO MISURATORE DI PRESSIONE	BASE MESUREUR DE PRESSION	PRESSURE GAUGE BLOCK	DRUCKMESSBLOCK	BLOQUE MEDIDOR DE PRESIÓN	
25	3223721	ATTACCO A CAMME	RACCORD À CAMES	CAM COUPLING	NOCKENANSCHLUSS	RACOR TIPO CAMLOCK	DN25 M-1" GM
26	3223392	MEMBRANA	MEMBRANE	MEMBRANE	MEMBRAN	MEMBRANA	
27	3225902	DISTANZIALE	CALE	GAUGE	DICKE	ESPEJOR	3mm
28	3224173	RIDUZIONE M.1-1/2" F.1/2" OTTONE	RÉDUCTION M.1-1/2" F.1/2" LAITON	M. REDUCTION 1-1/2" F.1/2" BRASS	REDUZIERSTÜCK M.1-1/2" F.1/2" MESSING	REDUCCIÓN M. 1-1/2" H.1/2" LATÓN	
29	3224928	NIPLES RIDOTTO 1/2"-3/8"	NIPLES REDUIT 1/2"-3/8"	REDUCED NIPPLE 1/2"-3/8"	NIPPLE REDUZIERSTÜCK 1/2"-3/8"	NIPLE REDUCTOR 1/2"-3/8"	
30	3224766	PRESSOSTATO FF 142-8 DAH 1/4 G	PRESSOSTAT FF 142-8 DAH 1/4 G	PRESSURE SWITCH FF 142-8 DAH 1/4 G	DRUCKWÄCHTER FF 142-8 DAH 1/4 G	PRESOSTATO FF 142-8 DAH 1/4 G	
31	1107545	COMANDO A DISTANZA	COMMANDE À DISTANCE	REMOTE CONTROL	FERNSTEUERUNG	MANDO A DISTANCIA	16Mt
32	3226830	INTERRUTTORE COMPLETO	INTERRUPTEUR COMPLETE	COMPLETE SWITCH	SCHALTER KOMPLETT	CIERRE COMPLETO	
33	3227170	SPINA 3P+T 110V 16A IP44	FICHE 3P+T 110V 16A IP44	PLUG 3P+T 110V 16A IP44	WANDSTECKER 3P+T 110V 16A IP44	ENCHUFE DE 3P+T 110V 16A IP44	
34	3226930	MANOPOLA INTERRUTTORE	POIGNÉE	HANDLE	GRIFF	MANILLA	
35	3226931	PULSANTE	INTERRUPTEUR	SWITCH	SCHALTER	CIERRE	
36	3226932	PROTEZIONE PULSANTE	PROTECTION	CAP	SCHUTZ	CASQUILLO	
37	1107544	PROLUNGA	PROLONGE ÉLECTRIQUE	PROLONGS ELECTRIC	VERLÄNGERUNG ELEKTRISCH	PROLONGA ELÉCTRICO	15Mt