

SYNTESI

190 - 250 - 300 - 350 EL

(1105650 - 1105650/A - 1105700 - 1105750 - 1105800 - 1105800/A) 230V/50Hz
 (1105701 - 1105752 - 1105801) 220V/60Hz
 (1105703 - 1105803) 110V/50Hz
 (1105655 - 1105705 - 1105755 - 1105805) 380V/50Hz
 (1105802) 115V/60Hz

I

BETONIERA

Manuale di uso, manutenzione e ricambi

F

BETONIERRE

Manuel utilisation entretien pieces de rechange

GB

CONCRETE MIXER

Operating, maintenance, spare parts manual

D

BETONMISCHER

Handbuch für Bedienung, Wartung und Ersatzteile

E

HORMIGONERA

Manual de uso, mantenimiento y recambios



3228768 R11 - 2018/02

Documentazione senza certificazione CE
Documentation without CE certificate

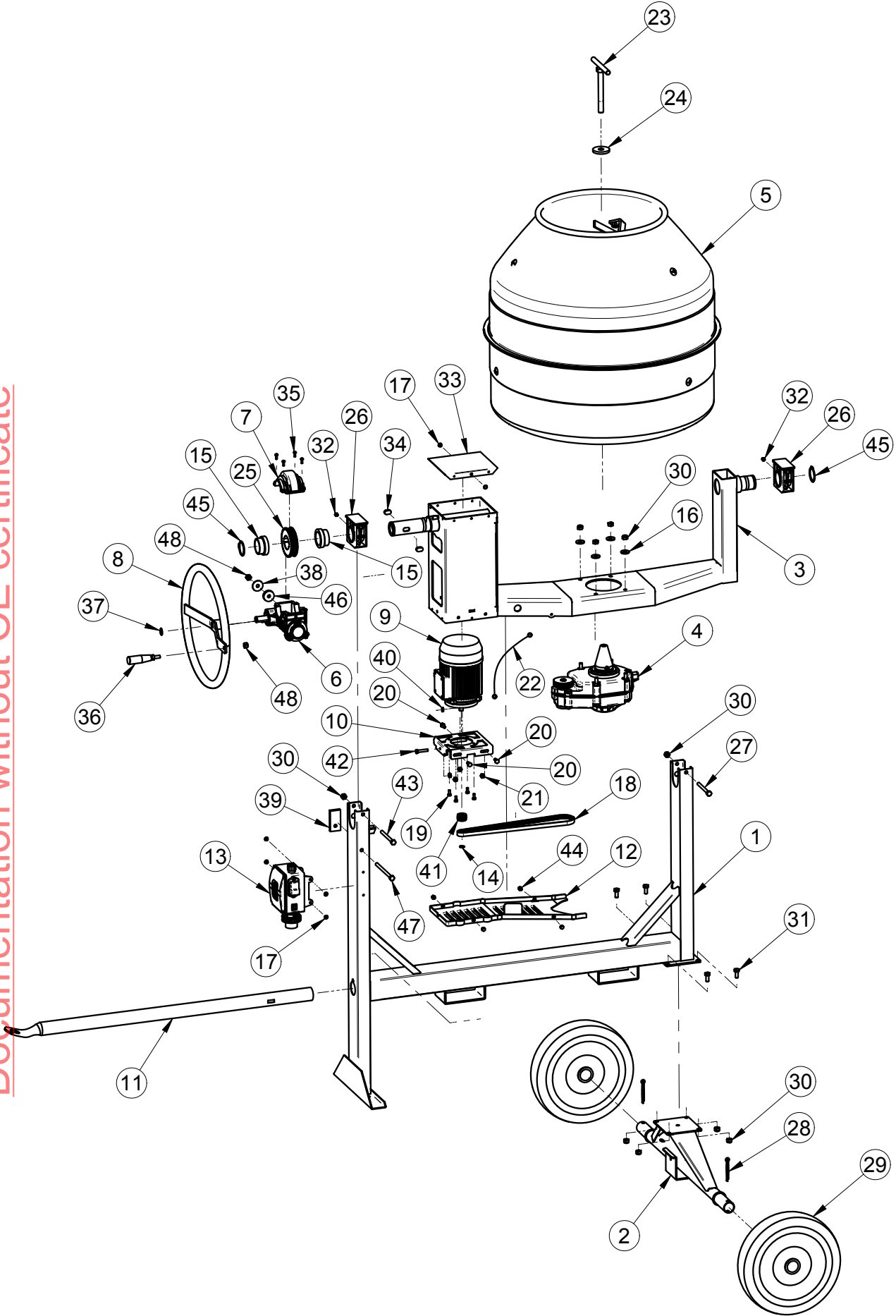

TAV. 1/A - 1/B



TAV. 1/A		STRUTTURA DELLA MACCHINA - STRUCTURE MACHINE - MACHINE STRUCTURE - MASCHINENAUFBAU ESTRUCTURA DE LA MAQUINA - [SYNTESI 190-250]					
RIF.	COD.	I	F	GB	D	E	NOTE
1	3208817	TELAIO	CHÂSSIS	FRAME	RAHMEN	BASTIDOR	
2	3228743	ASSALE RUOTE	ESSIEU ROUES	WHEEL AXLE	RADACHSE	EJE RUEDAS	COD. 1105650 - 1105650A-1105655
	3228744						COD. 1105700 - 1105701 1105703-1105705
3	3208782	BRACCIO	BRAS	ARM	ARM	BRAZO	
4	3208746	RIDUTTORE	REDUCTEUR	GEAR BOX	GETRIEBE	REDUCTOR	
	3210691						1105701
5	3208830	VASCA COMPLETA	CUVE TOUTE ÉQUIPÉE	COMPLETE TANK ASSEMBLY	KOMPLETTE WANNE	CUBA COMPLETA	COD. 1105650 - 1105655
	3208811						COD. 1105700 - 1105701 1105703 - 1105705
6	3209786	RIDUTTORE RIBALTAMENTO VASCA	RÉDUCTEUR DE BASCULEMENT DE LA CUVE	DRUM MOVEMENT REDUCTION UNIT	UNTERSETZUNGSGETRIEBE DER KIPPVORRICHTUNG DER MISCHTROMMEL	REDUCTOR VOLTEO DEL TAMBOR	1105650-
7	3209429	COPERCHIO	CAPOT	COVER	ABDECKUNG	CUBIERTA	
8	3228750	VOLANTE	VOLANT	HANDWHEEL	SCHWUNGRAD	VOLANTE	
9	3234487	MOTORE	MOTEUR	MOTOR	MOTOR	MOTOR	COD. 1105650 - 1105700
	3210698						COD. 1105703
	3209552						COD. 1105655 - 1105705
	3234487						COD. 1105650-A
	3228382						COD. 1105701
10	3208804	SUPPORTO MOTORE	SUPPORT DU MOTEUR	MOTOR SUPPORT	MOTORHALTERUNG	SOPORTE MOTOR	
11	3228745	TIMONE	BARRE	TOW BAR	STEUER	TIMON	
12	3208795	CARTER	CARTER	GUARD	SCHUTZHAUBE	CUBIERTA	
13	3229075	QUADRO ELETTRICO	TABLEAU ELECTRIQUE	ELECTRIC PANEL	SCHALTSCHRANK	CUADRO ELÉCTRICO	COD. 1105650 - 1105650A - 1105700 1105701
	3210700						COD. 1105703
	3228436						COD. 1105655 - 1105705
14	2227214	ANELLO ARRESTO	BAGUE D'ARRET	STOP RING	SPERRING	ANILLO DE TOPE	E 14
15	3208770	BOCCOLA	DOUILLE	BUSHING	BUCHSE	ANILLO	
16	3203917	RONDELLA	RONDELLE	WASHER	UNTERLEGSCHLEIBE	ARANDELA	D. 8X25X4 Z
17	3211175	RIVETTO	RIVET	RIVET	ALIUNET	REMACHE	STAVEX 4.8 TL ACC
18	3208791	CINGHIA	COURROIE	BELT	RIEMEN	CORREA	
19	2222002	VITE	VIS	BOLT	SCHRAUBE	TORNILLO	TE 8.8 5739 M6X16 Z
20	2222064	VITE	VIS	BOLT	SCHRAUBE	TORNILLO	TE 8.8 5739 M8X16 Z
21	2223570	DADO	ECROU	NUT	MUTTER	TUERCA	5588 M8 z
22	3208876	CAVETTO TERRA	CABLE DE MASSE	CABLE GROUND	CABLE GROUND	CABLE A TIERRA	mm 300
23	3206690	VITE BLOCCAGGIO VASCA	VIS DE BLOCAGE DE LA CUVE	DRUM LOCKING SCREW	FESTSTELLSCHRAUBE MISCHTROMMEL	TORNILLO BLOQUEO CUBA	
24	3207225	RONDELLA	RONDELLE	WASHER	UNTERLEGSCHLEIBE	ARANDELA	D.61X19X8
25	3208773	INGRANAGGIO	ENGRENAGE	GEAR	ZAHNRAD	ENGRANAJE	
26	3208792	SUPPORTO	SUPPORT	SUPPORT	HALTERUNG	SOPORTE	
27	2222114	VITE	VIS	BOLT	SCHRAUBE	TORNILLO	TE 8.8 5737 M8X90 Z
28	2226700	COPIGLIA	GOUPILLE	SPLIT PIN	SPLINT	PASADOR	COD. 1105650- 1105650A - 1105655
	2226503						COD. 1105700 - 1105701 - 1105703 1105705 (1336 8X63 Z)
29	2211100	RUOTA	ROUE	WHEEL	RÄDER	RUEDA	COD. 1105650 1105650A- 1105655
	2211200						COD. 1105700 - 1105701 1105703 -1105705
30	2223923	DADO	ECROU	NUT	MUTTER	TUERCA	AUTOBL. 7474 M8
31	2222060	VITE	VIS	BOLT	SCHRAUBE	TORNILLO	TE 8.8 5739 M8X20 Z
32	2230350	INGRASSATORE	GRAISSEUR	GREASER	SCHMIERER	INYEKTOR DE LUBRIFICANTE	M8X1.25
33	3228746	CHIUSURA BRACCIO	FERMETURE DU BRAS	ARM CLOSURE	ARMVERSCHLUSS	CIERRE DEL BRAZO	
34	3208776	LINGUETTA	LANGUETTE	KEY	KEIL	LENGUETA	14X9X25
35	2222467	VITE	VIS	BOLT	SCHRAUBE	TORNILLO	TRIOB. TC PH M5X20
36	3206748	MANOPOLA	POIGNÉE	KNOB	KNOPF	POMO	M10
37	3225036	ANELLO ARRESTO	BAGUE D'ARRET	STOP RING	SPERRING	ANILLO DE TOPE	E 20 Z
38	2224220	RONDELLA	RONDELLE	WASHER	UNTERLEGSCHLEIBE	ARANDELA	6593 D.10X40 Z
39	3208944	AMMORTIZZATORE	AMORTISSEUR	SHOCK ABSORBER	STOSSDÄMPFER	AMORTIGUADOR	
40	3228116	LINGUETTA	LANGUETTE	KEY	KEIL	LENGUETA	5X5X16
41	3208828	PULEGGIA	POULIE	PULLEY	RIEMENSCHLEIBE	POLEA	
42	2222190	VITE	VIS	BOLT	SCHRAUBE	TORNILLO	TE 8.8 5739 M8X40 Z
43	2222112	VITE	VIS	BOLT	SCHRAUBE	TORNILLO	TE 8.8 5737 M8X100 Z
44	3225750	VITE	VIS	BOLT	SCHRAUBE	TORNILLO	TRIOB. TEFR M6X10 Z
45	2227205	ANELLO ARRESTO	BAGUE D'ARRET	STOP RING	SPERRING	ANILLO DE TOPE	E 50
46	3208790	AMMORTIZZATORE	AMORTISSEUR	SHOCK ABSORBER	STOSSDÄMPFER	AMORTIGUADOR	
47	3210606	VITE	VIS	BOLT	SCHRAUBE	TORNILLO	TE 8.8 5737 M10X160 Z
48	2223920	DADO	ECROU	NUT	MUTTER	TUERCA	AUTOBL. 7474 M10



TAV. 1/B		STRUTTURA DELLA MACCHINA - STRUCTURE MACHINE - MACHINE STRUCTURE - MASCHINENAUFBAU ESTRUCTURA DE LA MAQUINA - [SYNTESI 300-350]					
RIF.	COD.	I	F	GB	D	E	NOTE
1	3209021	TELAIO	CHÂSSIS	FRAME	RAHMEN	BASTIDOR	
2	3228747	ASSALE RUOTE	ESSIEU ROUES	WHEEL AXLE	RADACHSE	EJE RUEDAS	
3	3209022	BRACCIO	BRAS	ARM	ARM	BRAZO	
4	3210475	RIDUTTORE	REDUCTEUR	GEAR BOX	GETRIEBE	REDUCTOR	COD. 1105750 - 1105755 1105800 - 1105803 - 1105805
	3210691						COD. 1105752 - 1105801- 1105802
5	3209311	VASCA COMPLETA	CUVE TOUTE ÉQUIPÉE	COMPLETE TANK ASSEMBLY	KOMPLETTE WANNE	CUBA COMPLETA	COD. 1105750 - 1105752 1105755
	3206635						COD. 1105800 - 1105801- 1105802-1105803 1105805
6	3209786	RIDUTTORE RIBALTAMENTO VASCA	RÉDUCTEUR DE BASCULEMENT DE LA CUVE	DRUM MOVEMENT REDUCTION UNIT	UNTERSETZUNGSGETRIEBE DER KIPPVORRICHTUNG DER MISCHTROMMEL	REDUCTOR VOLTEO DEL TAMBOR	
7	3209429	COPERCHIO	CAPOT	COVER	ABDECKUNG	CUBIERTA	
8	3228750	VOLANTE	VOLANT	HANDWHEEL	SCHWUNGRAD	VOLANTE	
9	3234565	MOTORE	MOTEUR	MOTOR	MOTOR	MOTOR	COD. 1105750 - 1105800
	3210697						COD. 1105803
	3226678						COD. 1105752
	3228383						COD. 1105801
	3209560						COD. 1105755 - 1105805
	3210674						COD. 1105802
10	3209006	SUPPORTO MOTORE	SUPPORT DU MOTEUR	MOTOR SUPPORT	MOTORHALTERUNG	SOPORTE MOTOR	
11	3228748	TIMONE	BARRE	TOW BAR	STEUER	TIMÓN	
12	3209005	CARTER	CARTER	GUARD	SCHUTZHAUBE	CUBIERTA	
13	3229076	QUADRO ELETTRICO	TABLEAU ELECTRIQUE	ELECTRIC PANEL	SCHALTSCHRANK	CUADRO ELÉCTRICO	COD. 1105750 - 1105800
	3210699						COD. 1105803
	3209025						COD. 1105752
	3228320						COD. 1105755 - 1105805
	3231997						COD. 1105801
3210677	COD. 1105802						
14	2227214	ANELLO ARRESTO	BAGUE D'ARRET	STOP RING	SPERRING	ANILLO DE TOPE	E 14
15	3208770	BOCCOLA	DOUILLE	BUSHING	BUCHSE	ANILLO	
16	3209178	RONDELLA	RONDELLE	WASHER	UNTERLEGSSCHEIBE	ARANDELA	D. 10X30X4 Z
17	3211175	RIVETTO	RIVET	RIVET	ALIUNET	REMACHE	STAVEX 4.8 TL ACC
18	3235727	CINGHIA	COURROIE	BELT	RIEMEN	CORREA	220V/50 Hz
	3236052						115V/60Hz
19	2222002	VITE	VIS	BOLT	SCHRAUBE	TORNILLO	TE 8.8 5739 M6X16 Z
20	2222060	VITE	VIS	BOLT	SCHRAUBE	TORNILLO	TE 8.8 5739 M8X20 Z
21	2223570	DADO	ECROU	NUT	MUTTER	TUERCA	5588 M8 z
22	3230876	CAVETTO TERRA	CABLE DE MASSE	CABLE GROUND	CABLE GROUND	CABLE A TIERRA	mm 300
23	3210467	VITE BLOCCAGGIO VASCA	VIS DE BLOCAGE DE LA CUVE	DRUM LOCKING SCREW	FESTSTELLSCHRAUBE MISCHTROMMEL	TORNILLO BLOQUEO CUBA	
24	3210466	RONDELLA	RONDELLE	WASHER	UNTERLEGSSCHEIBE	ARANDELA	D.61X19X8
25	3208773	INGRANAGGIO	ENGRENAGE	GEAR	ZAHNRAD	ENGRANAJE	
26	3209009	SUPPORTO	SUPPORT	SUPPORT	HALTERUNG	SOPORTE	
27	1222694	VITE	VIS	BOLT	SCHRAUBE	TORNILLO	TE 8.8 5737 M10X110 Z
28	2226503	COPIGLIA	GOUPILLE	SPLIT PIN	SPLINT	PASADOR	1336 D.8X63 Z
29	2211250	RUOTA	ROUE	WHEEL	RÄDER	RUEDA	
30	2223920	DADO	ECROU	NUT	MUTTER	TUERCA	AUTOBL. 7474 M10
31	2222056	VITE	VIS	BOLT	SCHRAUBE	TORNILLO	TE 8.8 5739 M10X25 Z
32	2230350	INGRASSATORE	GRAISSEUR	GREASER	SCHMIERER	INJECTOR DE LUBRIFICANTE	M8X1.25
33	3228749	CHIUSURA BRACCIO	FERMETURE DU BRAS	ARM CLOSURE	ARMVERSCHLUSS	CIERRE DEL BRAZO	
34	3208776	LINGUETTA	LANGUETTE	KEY	KEIL	LENGUETA	14X9X25
35	2222465	VITE	VIS	BOLT	SCHRAUBE	TORNILLO	TRILOB. TC PH M5X15
36	3206748	MANOPOLA	POIGNÉE	KNOB	KNOPF	POMO	M10
37	3225036	ANELLO ARRESTO	BAGUE D'ARRET	STOP RING	SPERRING	ANILLO DE TOPE	E 20 Z
38	2224220	RONDELLA	RONDELLE	WASHER	UNTERLEGSSCHEIBE	ARANDELA	6593 D.10X40 Z
39	3208789	AMMORTIZZATORE	AMORTISSEUR	SHOCK ABSORBER	STOSSDÄMPFER	AMORTIGUADOR	
40	3228116	LINGUETTA	LANGUETTE	KEY	KEIL	LENGUETA	5X5X16
41	3208828	PULEGGIA	POULIE	PULLEY	RIEMENSCHLEIBE	POLEA	
42	2222190	VITE	VIS	BOLT	SCHRAUBE	TORNILLO	TE 8.8 5739 M8X40 Z
43	2222154	VITE	VIS	BOLT	SCHRAUBE	TORNILLO	TE 8.8 5737 M10X120 Z
44	3225750	VITE	VIS	BOLT	SCHRAUBE	TORNILLO	TRILOB. TEFR M6X10 Z
45	2227205	ANELLO ARRESTO	BAGUE D'ARRET	STOP RING	SPERRING	ANILLO DE TOPE	E 50
46	3208790	AMMORTIZZATORE	AMORTISSEUR	SHOCK ABSORBER	STOSSDÄMPFER	AMORTIGUADOR	
47	3210606	VITE	VIS	BOLT	SCHRAUBE	TORNILLO	TE 8.8 5737 M10X160 Z
48	2223920	DADO	ECROU	NUT	MUTTER	TUERCA	AUTOBL. 7474 M10

Documentazione senza certificazione CE

TAV. 2/A - 2/B

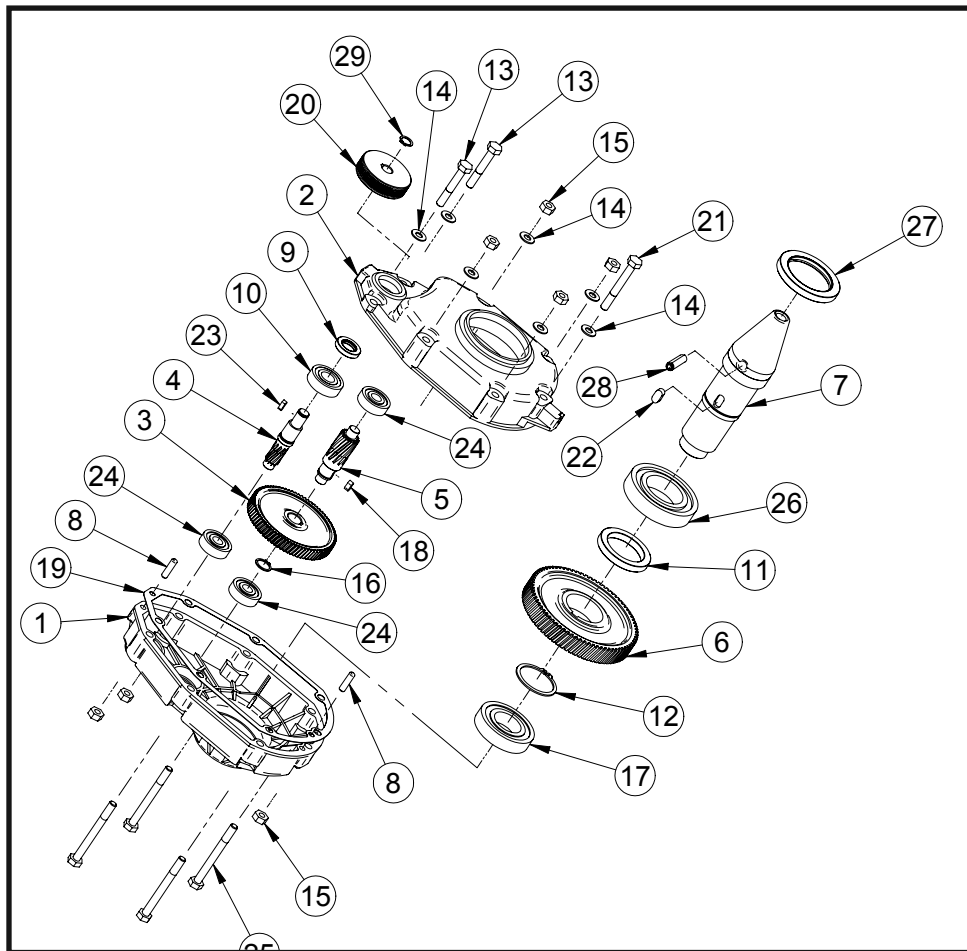

TAV. 2/A

RIDUTTORE - RÉDUCTEUR - GEAR BOX - GETRIEBE - REDUCTOR - [SYNTESI 190-250]

RIE.	COD.	I	F	GB	D	E	NOTE
	3208746						
1	3209680	CARCASSA RIDUTTORE	CARCASSE RÉDUCTEUR	GEAR BOX CASING	GETRIEBEGEHÄUSE	CARCASA REDUCTOR	
2	3209681	CARCASSA RIDUTTORE	CARCASSE RÉDUCTEUR	GEAR BOX CASING	GETRIEBEGEHÄUSE	CARCASA REDUCTOR	
3	2202493	INGRANAGGIO	ENGRENAGE	GEAR	ZAHNRAD	ENGRANAJE	
4	3209770	ALBERO	ARBRE	SHAFT	WELLE	EJE	
5	3208754	PIGNONE	PIGNON	PINION	RITZEL	PIÑÓN	
6	3208756	INGRANAGGIO	ENGRENAGE	GEAR	ZAHNRAD	ENGRANAJE	
7	3208748	ALBERO CENTRALE	ARBRE CENTRAL	MAIN SHAFT	ZENTRALANTRIEB	EJE CENTRAL	
8	2228820	SPINA	FICHE ÉLAASTIQUE	PIN	STIFT	CLAVIJA DE ACERO	D.6X14
9	3200094	ANELLO PARAOLIO	PARE-HUILE	OIL SEAL	ÖLDICHTUNG	GUARDAGOTAS	35X20X7
10	3225958	CUSCINETTO	ROULEMENT	BEARING	LAGER	COJINETE	6204
11	3208752	DISTANZIALE	ENTRETOISE	SPACER BRACKET	DISTANZHULSE	ESPACIADOR	
12	2227220	ANELLO ARRESTO	BAGUE D'ARRÊT	STOP RING	ARRETIERRING	ANILLO DE PARADA	E 40
13	2222018	VITE	VIS	BOLT	SCHRAUBE	TORNILLO	TE 8.8 5737 M8x35 Z
14	2224140	RONDELLA	RONDELLE	WASHER	UNTERLEGSCHIEBE	ARANDELA	6593 D.8X18 Z
15	2223570	DADO	ECROU	NUT	MUTTER	TUERCA	5588 M8 Z
16	2227220	ANELLO ARRESTO	BAGUE D'ARRÊT	STOP RING	ARRETIERRING	ANILLO DE PARADA	E 40
17	3213898	CUSCINETTO	ROULEMENT	BEARING	LAGER	COJINETE	6207
18	2229249	LINGUETTA	LANGUETTE	KEY	FEDER	LENGÜETA	5X5X12
19	3213887	GUARNIZIONE	JOINT	GASKET	DICHTUNG	JUNTA	
20	3208762 3210689	PULEGGIA	POULIE	PULLEY	RIEMENSCHIEBE	POLEA	1105701
21	2222114	VITE	VIS	BOLT	SCHRAUBE	TORNILLO	TE 8.8 5737 M8x90 Z
22	3213897	LINGUETTA	LANGUETTE	KEY	FEDER	LENGÜETA	10X8X15
23	2229250	LINGUETTA	LANGUETTE	KEY	FEDER	LENGÜETA	5X5X15
24	3209679	CUSCINETTO	ROULEMENT	BEARING	LAGER	COJINETE	6301
25	3227517	VITE	VIS	BOLT	SCHRAUBE	TORNILLO	TE 8.8 5739 M8x100 Z
26	3213899	CUSCINETTO	ROULEMENT	BEARING	LAGER	COJINETE	6209
27	3213896	ANELLO PARAOLIO	PARE-HUILE	OIL SEAL	ÖLDICHTUNG	GUARDAGOTAS	72X52X8
28	2228360	SPINA ELASTICA	FICHE ÉLASTIQUE	SHEAR PIN	SPANNSTIFT	CLAVIJA ELÁSTICA	D.8X16
29	1227330	ANELLO ARRESTO	BAGUE D'ARRÊT	STOP RING	ARRETIERRING	ANILLO DE PARADA	E 15

TAV. 2/B		RIDUTTORE - RÉDUCTEUR - GEAR BOX - GETRIEBE - REDUCTOR - [SYNTESI 300-350]					
3210475							
RIF.	COD.	I	F	GB	D	E	NOTE
1	3209514	CARCASSA RIDUTTORE	CARCASSE RÉDUCTEUR	GEAR BOX CASING	GETRIEBEGEHÄUSE	CARCASA REDUCTOR	
2	3209515	CARCASSA RIDUTTORE	CARCASSE RÉDUCTEUR	GEAR BOX CASING	GETRIEBEGEHÄUSE	CARCASA REDUCTOR	
3	3209801	INGRANAGGIO	ENGRENAGE	GEAR	ZAHNRAD	ENGRANAJE	
4	3209799	ALBERO	ARBRE	SHAFT	WELLE	EJE	
5	3208975	PIGNONE	PIGNON	PINION	RITZEL	PIÑÓN	
6	3208970	INGRANAGGIO	ENGRENAGE	GEAR	ZAHNRAD	ENGRANAJE	
7	3210474	ALBERO CENTRALE	ARBRE CENTRAL	MAIN SHAFT	ZENTRALANTRIEB	EJE CENTRAL	
8	3213180	SPINA	FICHE ÉLASTIQUE	PIN	STIFT	CLAVIJA DE ACERO	D.8X30
9	3200094	ANELLO PARAOLIO	PARE-HUILE	OIL SEAL	ÖLDICHTUNG	GUARDAGOTAS	35X20X7
10	3208983	CUSCINETTO	ROULEMENT	BEARING	LAGER	COJINETE	6204
11	3208966	DISTANZIALE	ENTRETOISE	SPACER BRACKET	DISTANZHULSE	ESPACIADOR	
12	2227207	ANELLO ARRESTO	BAGUE D'ARRÊT	STOP RING	ARRETIERRING	ANILLO DE PARADA	E 55
13	2222148	VITE	VIS	BOLT	SCHRAUBE	TORNILLO	TE 8.8 5737 M10X65 Z
14	2224340	RONDELLA	RONDELLE	WASHER	UNTERLEGSCHIEBE	ARANDELA	6592 D.10X21
15	2223650	DADO	ECROU	NUT	MUTTER	TUERCA	5588 M10 Z
16	2227320	ANELLO ARRESTO	BAGUE D'ARRÊT	STOP RING	ARRETIERRING	ANILLO DE PARADA	E 20
17	3213282	CUSCINETTO	ROULEMENT	BEARING	LAGER	COJINETE	6208
18	2229259	LINGUETTA	LANGUETTE	KEY	FEDER	LENGÜETA	6X6X14
19	3209811	GUARNIZIONE	JOINT	GASKET	DICHTUNG	JUNTA	
20	3235725	PULEGGIA	POULIE	PULLEY	RIEMENSCHIEBE	POLEA	220V/50 Hz
	3210688						115V/60Hz
21	2222145	VITE	VIS	BOLT	SCHRAUBE	TORNILLO	TE 8.8 5737 M10x80 Z
22	3213178	LINGUETTA	LANGUETTE	KEY	FEDER	LENGÜETA	10X8X20
23	2229250	LINGUETTA	LANGUETTE	KEY	FEDER	LENGÜETA	5X5X15
24	3209682	CUSCINETTO	ROULEMENT	BEARING	LAGER	COJINETE	6302
25	2222153	VITE	VIS	BOLT	SCHRAUBE	TORNILLO	TE 8.8 5737 M10x100 Z
26	2204569	CUSCINETTO	ROULEMENT	BEARING	LAGER	COJINETE	6211
27	3213179	ANELLO PARAOLIO	PARE-HUILE	OIL SEAL	ÖLDICHTUNG	GUARDAGOTAS	90X65X10
28	3213177	SPINA ELASTICA	FICHE ÉLASTIQUE	SHEAR PIN	SPANNSTIFT	CLAVIJA ELÁSTICA	6873 D.12X40
29	1227330	ANELLO ARRESTO	BAGUE D'ARRÊT	STOP RING	ARRETIERRING	ANILLO DE PARADA	E 15

TAV. 3

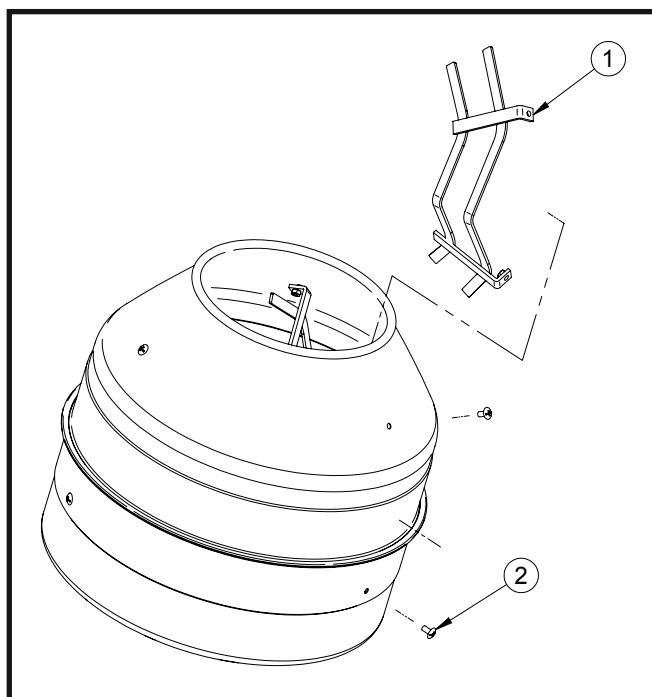

TAV. 3		VASCA IN ACCIAIO - CUVE EN ACIER - STEEL DRUM - MISCHTROMMEL AUS STAHL - CUBA DE ACERO					
RIF.	COD.	I	F	GB	D	E	NOTE
1	2250069	PALA	PALE	PADDLE	RÜHRARM	PALA	COD. 1105650 - 1105655
	2250087						COD. 1105700 - 1105703 - 1105705
	2250088						COD. 1105750 - 1105755
	2250089						COD. 1105800 - 1105803 - 1105805
2	2222193	VITE	VIS	BOLT	SCHRAUBE	TORNILLO	TB M12x25

TAV. 4

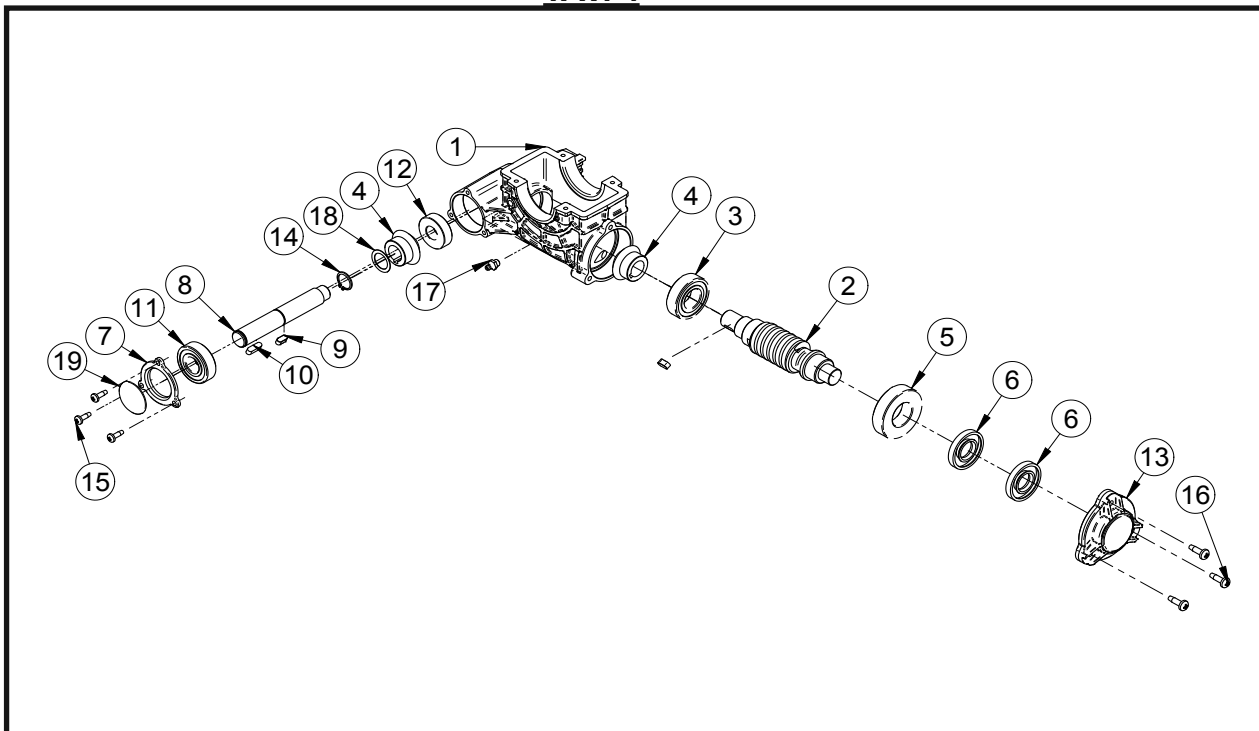

TAV. 4		RIDUTTORE RIBALTAMENTO VASCA - RÉDUCTEUR DE BASCULEMENT - DRUM REDUCTION UNITUNTERSETZUNGSGETRIEBE DER KIPPVORRICHTUNG DER MISCHTROMME REDUCTOR VOLTEO DEL TAMBUR					
3209786							
RIF.	COD.	I	F	GB	D	E	NOTE
1	3234639	CARCASSA RIBALTAMENTO	CARCASSE RÉDUCTEUR	GEAR BOX CASING	GETRIEBEGEHÄUSE	CARCASA REDUCTOR	
2	3213893	VITE SENZA FINE	VIS	BOLT	SCHRAUBE	TORNILLO	M10X110 Z
3	2204540	CUSCINETTO	ROULEMENT	BEARING	LAGER	COJINETE	
4	3213264	PIGNONE CONICO	PIGNON	PINION	RITZEL	PIÑÓN	Z 20
5	3208952	CUSCINETTO	ROULEMENT	BEARING	LAGER	COJINETE	
6	3213811	ANELLO PARAOLIO	BAGUE D'ÉTANCHÉITÉ	OIL SEAL RING	ÖLABSTREIFRING	ANILO DE RÉTEN	47X17X7
7	3234642	COPERCHIO RIDUTTORE	capot	cover	Abdeckung	cubierta	
8	3208771	ALBERO VOLANTE	ARBRE	SHAFT	WELLE	EJE	
9	2229259	LINGUETTA	LANGUETTE	KEY	FEDER	LENGÜETA	6X6X14
10	2229300	LINGUETTA	LANGUETTE	KEY	FEDER	LENGÜETA	6X6X20
11	2204560	CUSCINETTO	ROULEMENT	BEARING	LAGER	COJINETE	
12	3232764	CUSCINETTO	ROULEMENT	BEARING	LAGER	COJINETE	
13	3234641	COPERCHIO RIDUTTORE	capot	cover	Abdeckung	cubierta	
14	2227320	ANELLO SEEGER	BAGUE D'ARRÉT	STOP RING	ARRETIERRING	ANILLO DE PARADA	
15	2222465	VITE	VIS	BOLT	SCHRAUBE	TORNILLO	
16	3209987	VITE	VIS	BOLT	SCHRAUBE	TORNILLO	
17	2230350	INGRASSATORE	GRAISSE	GREASE	GREASE	GRASA	
18	3227876	ROSETTA	RONDELLE	WASHER	UNTERLEGSCHIEBE	ARANDELA	
19	3234355	ANELLO ARRESTO	BAGUE D'ARRÉT	STOP RING	ARRETIERRING	ANILLO DE PARADA	

TAV. 5

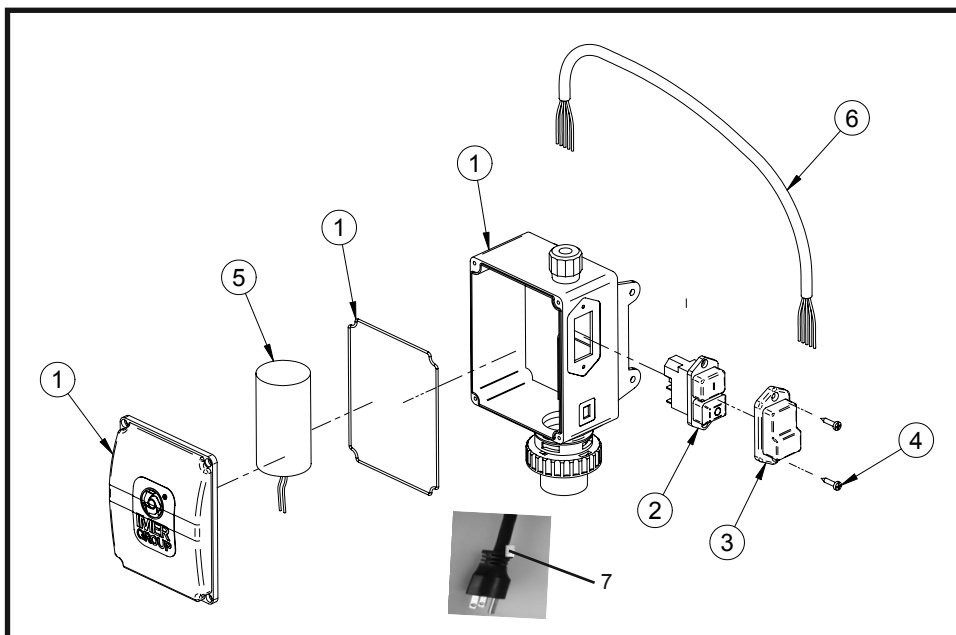

TAV. 5		QUADRO ELETTRICO MONOFASE - TABLEAU ELECTRIQUE MONOPHAS - SINGLE-PHASE ELECTRICAL PANEL					
		SCHALTTAFEL EINPHASENVERSORGUNG - CUADRO ELÉCTRICO MONOFÁSICO					
RIF.	COD.	I	F	GB	D	E	NOTE
1	3228752	CASSETTA ELETTRICA	BOÎTIER ÉLECTRIQUE	JUNCTION BOX	GEHÄUSE	CAJA ELÉCTRICA	COD. 1105650 - 1105700
	3228754						COD. 1105703
	3228753						COD. 1105750 - 1105752 - 1105800 - 1105801 (1105800-A Version Australia)
	3228755						COD. 1105803
	3234949						COD. 1105802
2	3209337	INTERRUTTORE	INTERRUPTEUR	SWITCH	SCHALTER	INTERRUPTOR	COD. 1105650 - 1105700 - 1105750 - 1105752 - 1105800 - 1105801 - 1105801 (1105800-A Version Australia)
	3210872						COD. 1105703 - 1105803
	3234950						COD. 1105802
3	3209340	PROTEZIONE TRASPARENTE	PROTECTION TRASPARENTE	LEAKAGE PROTECTION	PROTECCIÓN TRASPARENTE	PROTECCION	
4	3210116	VITE	VIS	BOLT	SCHRAUBE	TORNILLO	
5	3229078	CONDENSATORE	CONDENSATEUR	CAPACITOR	KONDENSATOR	CONDENSADOR	COD. 1105650 - 1105700 (450V 35µF)
	3213013						COD. 1105703 (250V 120µF)
	3229080						COD. 1105750 - 1105800 (450V 60µF)
	3210707						COD. 1105803 (250V 110µF)
	3209504						COD. 1105752 (1105800-A Version Australia) (450V 50µF)
	3231995						COD. 1105801 (450V 60 µF)
	3229797						COD. 1105802 (250V 100 µF)
6	3226030	CAVO ELETTRICO	CÂBLE ÉLECTRIQUE	ELECTRIC CABLE	STROMKABEL	CABLE ELÉCTRICO	COD. 1105650 - 1105700 - 1105750 - 1105752 - 1105800 - 1105801 - 1105801 - (1105800/A)
	3228762						COD. 1105703 - 1105803 - 1105802
7	3209542	SPINA PER USA	CHEVILLA	PIN	STECKER	CLAVIJA	1105802

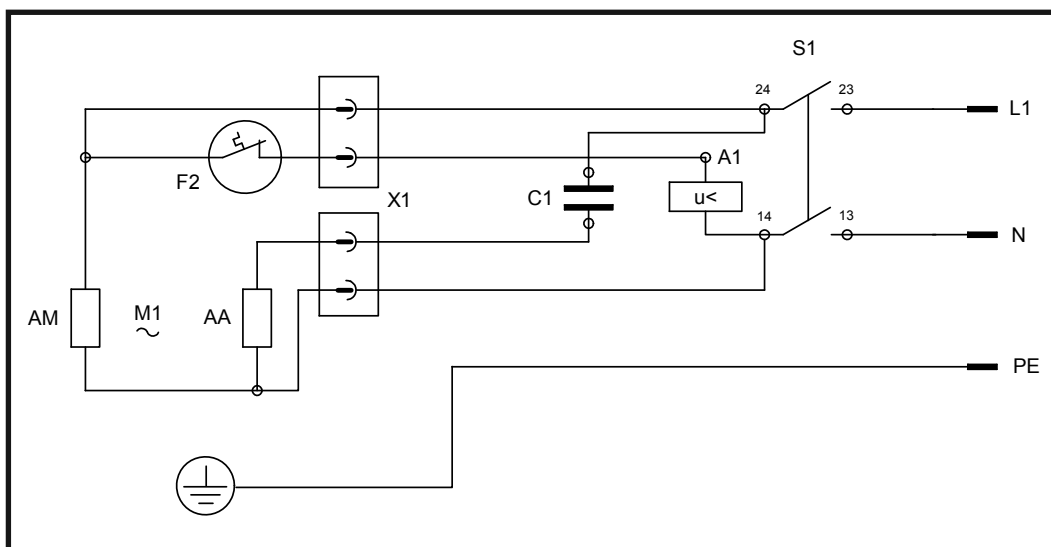

**SCHEMA ELETTRICO MONOFASE - SCHMA LECTRIQUE MONOPHAS - SINGLE-PHASE WIRING DIAGRAM
STROMLAUFPLAN EINPHASENVERSORGUNG - ESQUEMA ELÉCTRICO MONOFÁSICO**

RIF.	I	F	GB	D	E
PE	CONDUTTORE DI PROTEZIONE	CONDUCTEUR DE PROTECTION	PROTECTION WIRE	SCHUTZLEITER	CONDUCTOR DE LÍNEA PROTECCIÓN
N	CONDUTTORE LINEA NEUTRO	CONDUCTEUR LIGNE NEUTRE	NEUTRAL LINE CABLE	NULLEITER	CONDUCTOR DE LA LÍNEA DEL NEUTRO
L1	CONDUTTORE LINEA FASE	CONDUCTEUR LIGNE PHASE	PHASE LINE CONDUCTOR	PHASENLEITER	CONDUCTOR DE LA LÍNEA DE FASE
S1	INTERRUPTORE COMANDO	INTERRUPTEUR DE COMMANDE	CONTROL SWITCH	SCHALTER	INTERRUPTOR DE MANDO
F2	PROTEZIONE TERMICA	PROTECTION THERMIQUE	THERMAL PROTECTION	WÄRMESCHUTZ	PROTECCIÓN TÉRMICA
X1	MORSETTIERA MOTORE	BRIDES MOTEUR	MOTOR TERMINAL STRIP	KLEMMLEISTE MOTOR	CAJA DE BORNES MOTOR
C1	CONDENSATORE	CONDENSATEUR	CAPACITOR	KONDENSATOR	CONDENSADOR
M1	MOTORE	MOTEUR	MOTOR	MOTOR	MOTOR
AM	AVVOLGIMENTO MOTORE MARCIA	ENROULEMENT DU MOTEUR DE MARCHE	MOTOR RUNNING WINDING	MOTORWICKLUNG BETRIEB	ENROLLAMIENTO MOTOR MARCHA
AV	AVVOLGIMENTO MOTORE AVVIAMENTO	ENROULEMENT DU MOTEUR DE DÉMARRAGE	MOTOR START WINDING	MOTORWICKLUNG START	ENROLLAMIENTO MOTOR ARRANQUE

TAV. 6

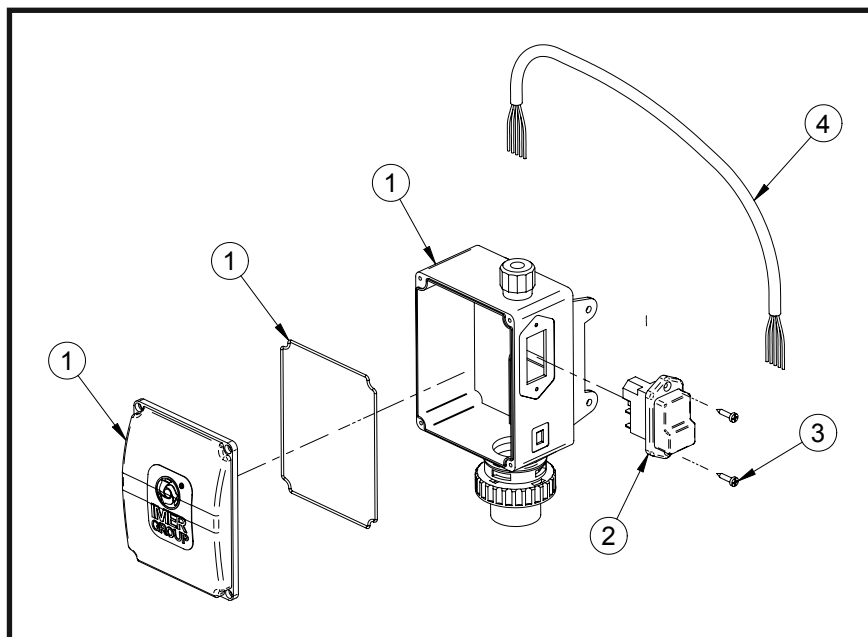

TAV. 6		QUADRO ELETTRICO TRIFASE - TABLEAU LECTRIQUE TRIPHAS - THREE-PHASE ELECTRICAL PANEL SCHALTAFEL WECHSELSTROMVERSORGUNG - CUADRO ELÉCTRICO TRIFÁSICO					NOTE
RIF.	COD.	I	F	GB	D	E	
1	3228759 3228760	CASSETTA ELETTRICA	BOÎTIER ÉLECTRIQUE	JUNCTION BOX	GEHÄUSE	CAJA ELÉCTRICA	COD. 1105655 - 1105705 COD. 1105755 - 1105805
2	3228761	INTERRUTTORE	INTERRUPTEUR	SWITCH	SCHALTER	INTERRUPTOR	
3	3210116	VITE	VIS	BOLT	SCHRAUBE	TORNILLO	
4	3228763	CAVO ELETTRICO	CÂBLE ÉLECTRIQUE	ELECTRIC CABLE	STROMKABEL	CABLE ELÉCTRICO	

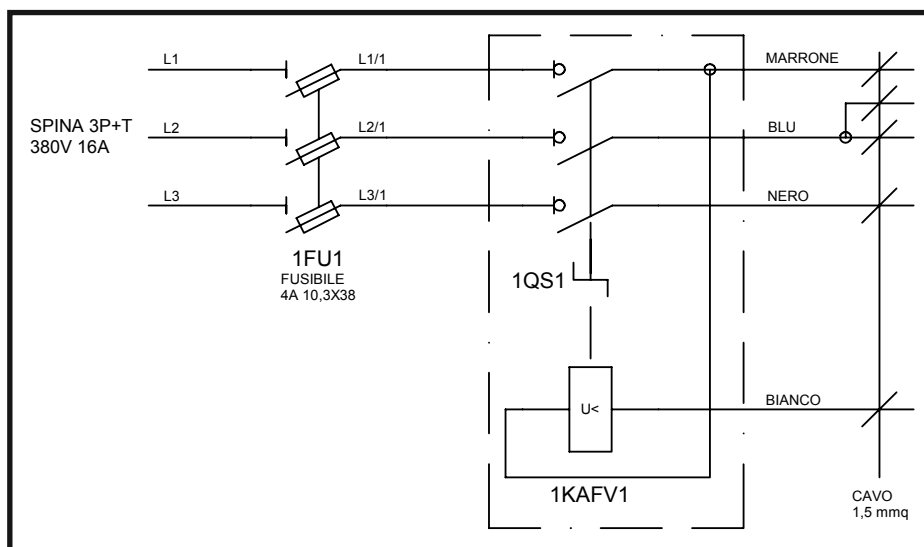

SCHEMA ELETTRICO TRIFASE - SCHMA LECTRIQUE TRIPHAS - THREE-PHASE WIRING DIAGRAM STROMLAUFPLAN WECHSELSTROMVERSORGUNG - ESQUEMA ELÉCTRICO TRIFÁSICO					
RIF.	I	F	GB	D	E
L1/L2/L3	CONDUTTORE LINEA FASE	CONDUCTEUR LIGNE PHASE	PHASE LINE CONDUCTOR	PHASENLEITER	CONDUCTOR DE LA LÍNEA DE FASE
1QS1	INTERRUTTORE COMANDO	INTERRUPTEUR DE COMMANDE	CONTROL SWITCH	SCHALTER	INTERRUPTOR DE MANDO
1FU1	PORTAFUSIBILE	PORTEFUSIBILE	FUSE CARRIER	POLKLEMME	BORNE
1KAFV1	PROTEZIONE TERMICA	PROTECTION THERMIQUE	THERMAL PROTECTION	WÄRMESCHUTZ	PROTECCIÓN TÉRMICA

Documentation without CE certification